

SB 201

Moisture-Density Specialist

CERTIFICATION MANUAL



**Partners
in Quality**





The Hot Mix Asphalt Center exists to certify, train, and equip specialists with the knowledge and skills needed to inspect, test, and design construction materials. Through education and support that continue beyond certification, the HMACE seeks to help people realize their potential to contribute to the future of Texas' infrastructure.

To execute our mission, we constantly aim to:

EDUCATE

Through hands-on learning, training, and testing, our instructors ensure specialists not only have a thorough understanding of the subject, but will be able to apply what they've learned in a real-world setting. We believe our role as an educational resource doesn't stop at the door – it continues throughout a specialist's career.

INNOVATE

From installing the latest, cutting-edge equipment in our labs to streamlining processes and developing new educational tools, we strive to continuously set a higher bar for ourselves and those around us.

EMPOWER

We believe in the potential of every specialist who comes through the center and do all we can to help them be successful before, during, and after certification. Our mantra is that what you do matters. If you put in the work to be the best you can be, we'll be here to cheer you on and support you along the way.

SERVE

Service is at the core of everything we do. Whether it be for individuals, companies, TxDOT, or the traveling public, the goal is for every certification to result in improved quality of asphalt pavements across the state of Texas.



SB201 Moisture-Density Specialist

TABLE OF CONTENTS

Rights and Responsibilities

Website

Tex-101-E Preparing and Testing Soils and Base Materials (Part 2)

Tex-113-E Moisture-Density Curve for Base, Coarse, and Treated Materials

Tex-114-E Laboratory Compaction Characteristics and Moisture-Density Relationship of
Subgrade and Embankment Soils

Tex-120-E Soil-Cement Testing (Part 1)

Tex-121-E Soil-Lime Testing (Part 1)

Tex-142-E Laboratory Classification of Soils for Engineering Purposes

Item 247 Flexible Base

©2023 HMAC - All Rights Reserved

No part of this publication may be reproduced, stored in a retrieval system or transmitted in any form or by any means, mechanical, electronic, photocopying, recording or otherwise without the prior written permission of the Texas Asphalt Pavement Association.



HMAC CERTIFIED SPECIALIST & APPLICANTS FOR CERTIFICATION: RIGHTS AND RESPONSIBILITIES

This agreement (the "Agreement") affirms that, _____, the below Applicant for Certification or the current Certified Specialist (collectively, the "Specialist") seeks to meet or has successfully met the requirements for certification by the Texas Asphalt Pavement Association ("TXAPA"), a/k/a the Hot Mix Asphalt Center (HMAC) as a certified technician. In that connection, the Specialist agrees as follows:

RIGHTS AND RESPONSIBILITIES - HMAC certification includes the exclusive right to perform certified sampling, testing and reporting on Texas Department of Transportation (TxDOT) projects involving Hot Mix Asphalt (HMA) and Soils & Base (SB) in accordance with TxDOT specifications and test procedures (as may be amended by TxDOT from time to time) for the level of certification issued. Specialists are required to perform and report test results with the accuracy and precision required of a certificated HMA or SB Specialist. It is important that the Specialist fully understands the significance of performing these duties in accordance with the certification level received by the Specialist.

Each Specialist is responsible for performing their own independent sampling, testing and reporting in accordance with TxDOT specifications, test procedures and standard operating procedures. These duties must be performed in a diligent and professional manner to produce TxDOT projects of the highest possible quality.

CONTACT INFORMATION - It is the Specialist's responsibility to provide the HMAC with current contact information by logging into www.txhmac.org. Communications from the HMAC will primarily be sent electronically to the most recent contact information provided by the Specialist.

ANNUAL PROFICIENCY - Once certified, Specialists are required to complete annual proficiency testing and the reporting of results to the HMAC. The testing and reporting must be timely and independently performed by the Specialist and, where applicable, in conformance with the requirements of the Specialist's certifications. TxDOT will ship the annual proficiency samples to the Specialist's address of record. (If this address is not current, the Specialist may not timely receive a proficiency sample and his/her certification may be danger of lapsing.)

Failure to submit proficiency test results or to respond to low rating(s) by the appointed deadlines may result in a change of certification status from active to inactive. Specialists whose certifications are inactivated because their annual proficiency testing/reporting is not current or whose certifications have been revoked or inactivated are prohibited from performing the duties associated with all certifications held by that Specialist.

RECERTIFICATION - Certification(s) are valid for three (3) years from the date originally issued, after which the Specialist must be recertified by again passing the requirements for certification. Specialists may seek recertification up to one year prior to the expiration of their certificate(s).

Failure to timely obtain recertification will cause all dependent certifications held by a Specialist to be inactivated. It is the Specialist's responsibility to maintain an active certification(s). (The HMAC will not provide reminders of pending expiration dates.)

ALLEGATIONS OF MISCONDUCT - Allegations of misconduct should be submitted to the HMAC, P.O. Box 1468, Buda, TX 78610 and must include the name, address and signature of the individual asserting the allegations as well as a brief description of the allegations.

If the allegations are properly submitted and appear to have merit, the HMAC Steering Committee (the "Committee") the individual asserting misfeasance and the person so accused will be asked to meet in person (but at separate dates/times) with members of the Committee. At the conclusion of the meeting(s), the Committee will issue its determination.

Misconduct generally consists of (i) neglect, (ii) abuse and/or (iii) breach of trust which are generally defined as:

1. Neglect: unintentional deviation(s) from specifications or testing procedures;
2. Abuse: careless or deliberate deviation from specifications or testing procedures; and
3. Breach of Trust: violation of the trust placed in Certified Specialists including, but not limited to, acts such as:
 - a. Falsification of or deliberate omission from material records or information; or
 - b. Awareness of improprieties in sampling, testing and/or production by others and the failure to timely report those improprieties to the appropriate project supervision.

The Committee may issue written reprimands (private or public) and/or revoke or inactivate a certification (if the Specialist has made a false representation or misstatement to the Committee or to the public or has engaged in misconduct) or take such other actions as the Committee, in its sole discretion, determines to be appropriate with respect to the Specialist's certification(s).

Specialists who do not achieve recertification or whose certification is revoked or inactivated by the Committee may appeal to a separate appeals committee comprised of industry members (the "Appeal Committee"). The exhaustion of this right of appeal to the Appeal Committee is a prerequisite to the exclusive remedy of administrative review by final and binding arbitration in Hays County, Texas, as administered by the American Arbitration Association by a single-member panel. Any and all other claims related in any way to this Agreement are exclusively subject to final and binding arbitration in Hays County, Texas as administered by the American Arbitration Association by a single-member panel.

In consideration for the HMAC certification/recertification process, Specialist hereby waives any and all claims of whatsoever kind or character related, directly or indirectly, to this Agreement, against the TXAPA, HMAC (including, but not limited to, the Committee and the Appeal Committee and their members), that s/he may have (including claims for attorney's fees) and further agrees to save, indemnify and hold TXAPA, the HMAC (including, but not limited to, the Committee and the Appeal Committee and their members) harmless from any claim, action or cause of action arising as a result of, or relating to this Agreement including, but not limited to, Specialist's certification, or any refusal, reprimand, revocation and/or suspension of certification or recertification of Specialist.

ACKNOWLEDGED & AGREED:

SPECIALIST:

SIGNATURE

DATE

PRINTED NAME



WEBSITE

It is your responsibility to keep your information up-to-date.

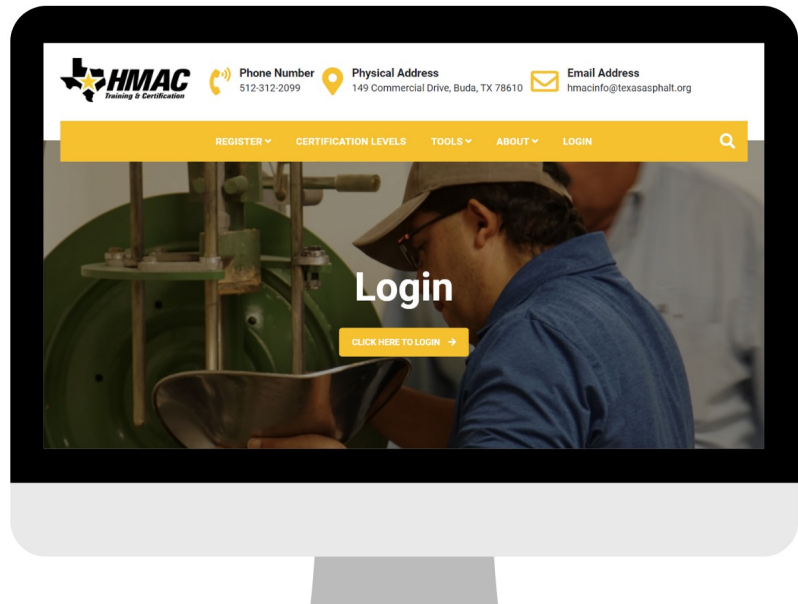

FIRST TIME LOGIN

Username

Capitalize the first letter of your first and last name then spell out the rest of your last name in lower case, followed by the last 4 digits of your SSN.

Password

Same as your username, but add a "+" at the end.

Example

If your name is John Doe and your SSN ends in 1234:

Username: JDoe1234

Password: JDoe1234+

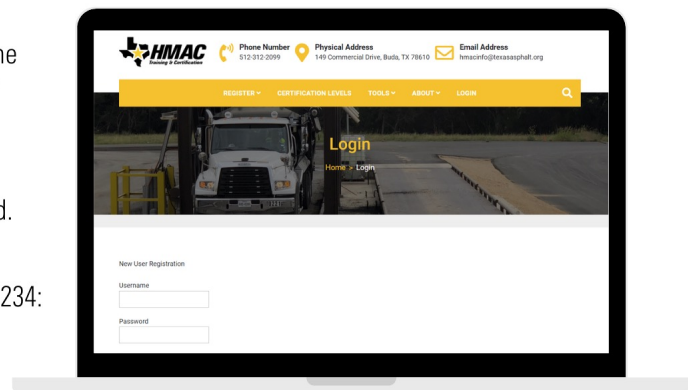

UPDATE INFORMATION

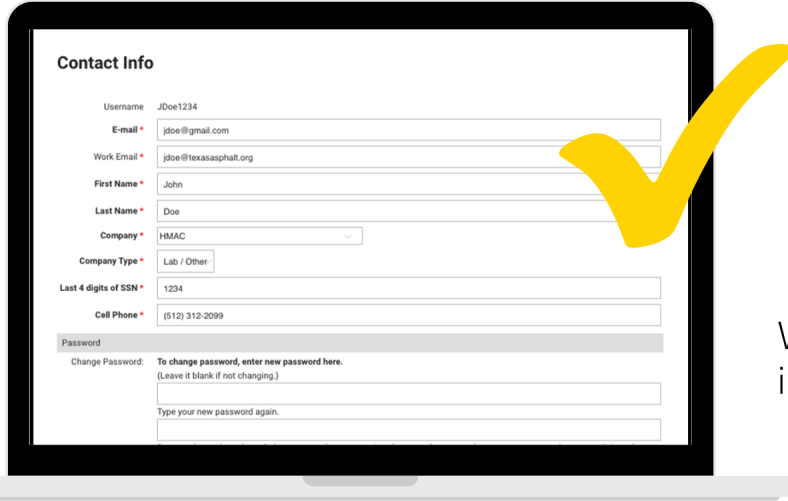

Contact Info

Username: J.Doe1234

E-mail:

Work Email:

First Name: John

Last Name: Doe

Company:

Company Type:

Last 4 digits of SSN:

Cell Phone:

Change Password:

Type your new password again:

Verify that all information is correct.

UPDATE INFORMATION

**VIEW/PRINT
CERTIFICATIONS
PROFICIENCY**

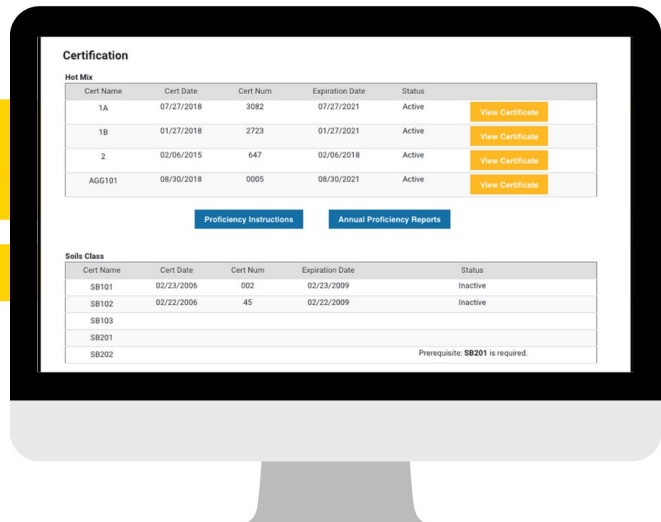

Certification

Hot Mix

Cert Name	Cert Date	Cert Num	Expiration Date	Status	
1A	07/27/2018	3982	07/27/2021	Active	View Certificate
1B	01/27/2018	2723	01/27/2021	Active	View Certificate
2	02/06/2015	647	02/06/2018	Active	View Certificate
AGG101	08/30/2018	0005	08/30/2021	Active	View Certificate

[Proficiency Instructions](#) [Annual Proficiency Reports](#)

Soils Class

Cert Name	Cert Date	Cert Num	Expiration Date	Status
SB101	02/23/2006	002	02/23/2009	Inactive
SB102	02/23/2006	45	02/22/2009	Inactive
SB103				
SB201				
SB202				

Prerequisite: SB201 is required.

Test Procedure for

PREPARING AND TESTING SOILS AND BASE MATERIALS

TxDOT Designation: Tex-101-E

Effective Date: April 2024**1. SCOPE**

- 1.1 This test method consists of three parts for the preparation and testing of embankment (soils), flexible base, roadway salvaged materials, and treated materials from the roadway or stockpile. Part I includes two methods, Method A and B. Method A is for dry preparation, and Method B for wet preparation. Part II is used for preparing untreated material for compaction, wet ball mill, and compression testing. Part III is used to measure the sieve analysis of road-mixed treated material, such as treatment with cement, emulsion, foamed asphalt, or lime.
- 1.2 Part I, Method A is used for preparing untreated material for liquid limit ([Tex-104-E](#)), plastic limit ([Tex-105-E](#)), plasticity index ([Tex-106-E](#)), linear bar shrinkage ([Tex-107-E](#)), and gradation ([Tex-110-E](#)). This method requires the sample to be oven-dried before preparation.
- 1.2.1 Part I, Method B may be used to prepare samples as received without oven-drying and is only allowed for samples to determine the liquid and plastic limit. Method B cannot be used to prepare samples for gradation testing.
- 1.2.2 Method A is the required method for referee testing and the preferred method to prepare materials. Methods A and B are only used to prepare samples that are not treated with an additive.
- 1.3 Part II is used to prepare samples for compaction ([Tex-113-E](#)), wet ball mill ([Tex-116-E](#)), and for compressive strength testing ([Tex-117-E](#)). This is used to determine the bulk gradation of the sampled base material.
- 1.4 Part III is used to determine the gradation of road-mixed material treated with an additive. This procedure uses sieves as required by the governing standard specification. The results are used to determine if adequate mixing and reclamation is achieved.
- 1.5 *This test procedure does not claim to address the safety concerns associated with its use. It is the responsibility of the user of this test procedure to establish the appropriate safety, health, and environmental practices and determine the applicability of regulatory limitations before use.*

2. APPARATUS AND MATERIALS

- 2.1 *Balance*, Class G2 in accordance with [Tex-901-K](#), minimum capacity 80 lb.
- 2.2 *Containers, metal pans, cardboard cartons.*
- 2.3 *Crusher*, optional to break down material passing the No. 40 sieve.

- 2.4 *Dispenser cup.*
- 2.5 *Filter paper, non-fibrous.*
- 2.6 *Mechanical mixer, stirring device.*
- 2.7 *Mortar and pestle.*
- 2.8 *Oven, capable of maintaining a temperature of $140 \pm 9^\circ\text{F}$ for Part I and $230 \pm 9^\circ\text{F}$ for Part II.*
- 2.9 *Plaster of Paris molds (optional).*
- 2.9.1 Dry the plaster of Paris molds at a **maximum** temperature of 140°F after forming, and wash and dry after each use.
- 2.10 *Scoop.*
- 2.11 *Sieves, square, wire cloth openings meeting the requirements of [Tex-907-K](#).*
- 2.12 *Splitter, quartering machine, or quartering cloth.*
- 2.13 *Water, approved drinking source.*

PART I—PREPARING SAMPLES FOR LIQUID LIMIT, PLASTIC LIMIT, AND GRADATION TESTING

3. DRY PREPARATION, METHOD A

- 3.1 Sample embankment (soils), flexible base, or roadway salvaged materials in accordance with [Tex-100-E](#).
- 3.1.1 When testing flexible base, prepare the sample in accordance with Section 6 of [Tex-100-E](#).
- 3.1.2 When testing the sample for the liquid and plastic limits or the linear bar shrinkage, split or quarter material to provide a minimum of 300 g of material passing the No. 40 sieve.
- 3.1.3 When testing the sample for gradation, split or quarter enough material to provide a minimum weight based on [Tex-110-E](#), Table 1, Minimum Sample Weight. This sample may also be used to test for the liquid and plastic limit to determine the plasticity index.
- 3.2 Dry the sample in an oven at $140 \pm 9^\circ\text{F}$ to constant weight.
- 3.2.1 Constant weight is achieved when the weight loss is less than 0.1% of the sample weight after 4 hr. of drying.
- 3.2.2 When using the material to test for [Tex-110-E](#), Part I, weigh the sample and record to the nearest 0.1 lb. This weight is the total sample weight before washing the material.
- 3.3 Dry sieve the material over a No. 40 sieve by hand or with a mechanical shaker.
- 3.4 Set aside and save the material passing the No. 40 sieve.
- 3.5 Slake the material retained on the No. 40 sieve in water.

- 3.5.1 Place the **dry** material into a **clean** pan.
- 3.5.2 Cover the material completely with water and soak for a minimum of 12 hr.
- 3.5.3 Decant or siphon off the clear water and take care not to lose any material.
- 3.5.4 Place **an** empty No. 40 sieve into a clean, **large** pan. **Additional pans may be necessary.**
- 3.5.5 **Pour** the liquid from the **soaked** sample through it.
- 3.5.6 Transfer the **soaked** sample to the sieve in increments **to avoid overloading the sieve.**
- 3.5.7 Pour water over the sieve until the water level is **approximately 1/2-in.** above the material.
- 3.5.8 **Agitate** the sieve up and down and stir the sample by hand **to pass the fines through the sieve.**
- 3.5.9 **When** the material retained on the sieve contains lumps that have not disintegrated, crumple any that can be broken down between thumb and fingers and wash through the sieve.
- 3.5.10 After the **fines** have passed through the sieve, wash the retained aggregates clean **while holding the sieve above the pan to capture any additional fines.**
- 3.5.11 When testing for gradation ([Tex-110-E](#)), transfer the retained aggregate from the sieve to a clean pan. **This material may be discarded when not testing for gradation.**
- 3.5.12 Repeat the procedure in Sections **3.5.6 – 3.5.11.** until all the soaked sample has been washed.
- 3.6 Dry the retained aggregate portion of the sample in an oven **at 140 ± 9°F** to **constant weight as defined** in Section **3.2.1.**
- 3.6.1 When testing for gradation, proceed to Section 3.7.
- 3.6.2 When testing for the **liquid and plastic limit**, proceed to Section 3.8.
- 3.7 When testing for gradation, determine the gradation of the **material retained on the No. 40 sieve** in accordance with [Tex-110-E](#), Part I.
- 3.8 Place the pan containing the wash water **and material passing the No. 40 sieve** aside until all the soil has settled to the bottom of the pan and the water above the soil is clear.
- 3.8.1 When the soil does not settle within 24 hr., proceed to Section 3.11.
- 3.9 Decant the water off the soil **and take care not to lose any material.**
- 3.10 Dry the remaining soil in **an** oven **at 140 ± 9°F** to constant weight as defined in Section 3.2.1. Proceed to Section 3.12.
- 3.11 **Evaporate** the water by placing the sample in **an** oven **at 140 ± 9°F** until it is dry or siphon the water on to a plaster of Paris mold lined with filter paper.
- 3.11.1 When the water has **evaporated or absorbed by the filter paper**, place the filter paper with adhering soil in a pan and dry in the oven **at 140 ± 9°F.**
- 3.11.2 Sweep the dry soil from the filter paper with a stiff brush into the pan of fines.

3.12 Break down the dried soil completely with a mortar and pestle or a suitable crusher.

3.13 Combine this material with the material from Sections 3.4.

3.14 Mix the material thoroughly to produce a uniform sample.

4. WET PREPARATION, METHOD B

4.1 Sample embankment (soils), flexible base, or roadway salvaged materials in accordance with [Tex-100-E](#).

4.1.1 When testing flexible base, prepare the sample in accordance with Section 6 of [Tex-100-E](#).

4.2 Split or quarter material to provide a minimum of 300 g of material passing the No. 40 sieve.

4.3 Place the sample in a clean pan.

4.4 Cover the material completely with water and soak for a minimum of 12 hr.

4.5 Place an empty No. 8 sieve into a clean, large pan.

4.6 Sieve the wet sample to remove large aggregate particles.

4.7 Wash the material retained on the sieve with a small amount of water.

4.8 Discard the portion of the material retained on the sieve.

4.9 When testing material with a low plasticity index (PI) such as 12 or less, proceed to Section 4.12.

4.10 When testing material with a moderate to high PI such as greater than 12, place the material into the dispersion cup of a mechanical mixer.

4.10.1 Do not fill the cup more than half-full.

4.10.2 Mix the material until the soil binder is separated.

4.11 Pour the material through a No. 40 sieve into a plaster of Paris bowl lined with filter paper.

4.11.1 Agitate the sieve up and down and stir the sample by hand to pass the fines through the sieve.

4.11.2 When the material retained on the sieve contains lumps that have not disintegrated, return them to the dispersion cup, and remix and wash through the sieve.

4.12 Pour until at least 95% of the soil binder has passed through the sieve.

4.13 Reduce the water content of the material in the plaster of Paris bowl to below the liquid limit.

4.14 When the sample can be divided into pie-like wedges and each wedge can be easily removed, it may be used for testing the liquid and plastic limit.

4.14.1 When the liquid and plastic limit are not to be determined immediately, place the material into an airtight container to prevent moisture loss.

PART II—PREPARING SAMPLES FOR COMPACTION, WET BALL MILL, AND COMPRESSIVE STRENGTH TESTING

5. PREPARING SAMPLES

- 5.1 Sample embankment (soils), flexible base, or roadway salvaged materials in accordance with [Tex-100-E](#).
- 5.1.1 When testing flexible base, prepare the sample in accordance with Article 6, "Preparing Flexible Base Samples for Testing," of [Tex-100-E](#).
- 5.2 When testing soils, spread the material on a clean floor and allow it to air dry to below the anticipated optimum moisture content or oven dry at a maximum temperature of 140°F.
- 5.2.1 Sieve the material using a 1/4 in. sieve, such that there are two sizes available for material retained and passing the 1/4 in. sieve.
- 5.2.1.1 When the material retained on the 1/4-in. sieve contains coarse aggregate, use coarser size sieves as deemed applicable and necessary to separate the material.
- 5.2.2 Process material that may have formed into hard lumps when dried or contain aggregate to pass through a 1/4-in. wire-mesh.
- 5.3 When testing base materials, oven dry the material at $230 \pm 9^{\circ}\text{F}$ to constant weight.
- 5.3.1 Constant weight is achieved when the weight loss is less than 0.1% of the sample weight after 4 hr. of drying.
- 5.3.2 Sieve base into the following sizes.
- 1-3/4 in.
 - 1-1/4 in.
 - 7/8 in.
 - 5/8 in.
 - 3/8 in.
 - No. 4
 - No. 40
- 5.3.2.1 Do not overload the sieves or screens. The material passing the No. 4 and retained on the No. 40 sieve may need to be sieved separately or in smaller batches to avoid overloading.
- 5.3.3 Weigh the material retained on each sieve and record to the nearest 0.1 lb.
- 5.3.4 Add all the weights retained to determine a total weight and record to the nearest 0.1 lb.
- 5.3.5 Calculate the bulk gradation for the percent retained on each sieve size using the equation in Section 7.1.

PART III—SIEVE ANALYSIS OF ROAD-MIX STABILIZED MATERIAL

6. PROCEDURE

- 6.1.1 Sample road-mixed material after mixing and before roller compaction in accordance with [Tex-100-E](#).
- 6.2 Use a sample splitter, quartering machine, or quartering cloth to reduce the sample size to a minimum of 10.0 lb.
- 6.3 Weigh the sample and record to the nearest 0.1 lb.
- 6.4 Use the sieve sizes required by the specification and arrange a set of sieves in descending order beginning with the largest size on top and a pan at the bottom.
- 6.5 Pour the sample into the top sieve and cover the stack of sieves and pan.
- 6.5.1 Do not overload the sieves or screens, may need to be sieved in smaller batches to avoid overloading.
- 6.6 Shake the set of sieves with a mechanical sieve shaker for 5 min. or by hand.
- 6.7 Shake each sieve size by hand to refusal.
- 6.7.1 Hand sieve for approximately 1 min. with lateral and vertical motion with a jarring action that keeps the material moving continuously over the surface of the sieve.
- 6.7.2 Continue hand sieving until no more than 1% of the test sample by weight passes through the sieve.
- 6.8 Weigh the material passing each sieve and record to the nearest 0.1 lb.
- 6.9 Calculate the percent passing each sieve using the equation in Section 7.2.

7. CALCULATION

- 7.1 Use the following equation to determine the percent retained for each sieve size.

$$\text{Percent Retained} = 100 \times \left[\frac{W_{\text{Retained}}}{W_{\text{Total}}} \right]$$

Where:

W_{Retained} = Weight of material retained on the sieve from Section 5.4.3.

W_{Total} = Total weight of the test sample from Section 5.4.4.

- 7.2 Use the following equation to determine the percent passing for each sieve size.

$$\text{Percent Passing} = 100 \times \left[\frac{W_{\text{Passing}}}{W_{\text{Total}}} \right]$$

Where:

W_{Passing} = Weight of material passing the sieve from Section 6.8.

W_{Total} = Total weight of the test sample from Section 6.3.

8. REPORT

8.1 Report test results to the nearest whole percent.

9. ARCHIVED VERSIONS

9.1 Archived versions are available.

Test Procedure for

MOISTURE-DENSITY CURVE FOR BASE, COARSE, AND TREATED MATERIALS

TxDOT Designation: Tex-113-E

Effective Date: **January 2025****1 SCOPE**

- 1.1 This procedure produces a moisture-density curve for flexible base, coarse-grained materials containing particles larger than 7/8 in., and treated embankment (soils) and base materials that are plant or road-mixed. Coarse-grained materials may include embankment (soil) and retaining wall backfill. Treated materials includes any material that is plant or road-mixed with an approved additive such as cement, emulsion, foamed asphalt, or lime. This procedure also applies to materials mixed with non-approved additives.
- 1.2 Sampled material is compacted using an automatic tamper (compaction) device into a mold to produce a molded specimen with a diameter of 6 in. and a height of 8 in. It compacts material in 4 lifts with a 10 lb. hammer and 18 in. drop height. A slide finishing hammer is used to ensure the top surface of the mold is level.
- 1.3 The compaction device is equipped with a Soil Compactor Analyzer (SCA). The SCA monitors and records the compacted effort of the molded specimen to ensure the required total energy of 750 ± 15 ft.-lb. is achieved within 50 – 60 blows for each lift.
- 1.4 The density and moisture content of compacted molds are used to produce a moisture-density curve. This will provide a maximum dry density and an optimum moisture content. The maximum dry density is the peak of this curve. The optimum moisture-content is the moisture content at the maximum dry density. This is the water content at which material can be compacted to achieve the maximum dry density.
- 1.5 *This test procedure does not claim to address the safety concerns associated with its use. It is the responsibility of the user of this test procedure to establish the appropriate safety, health, and environmental practices and determine the applicability of regulatory limitations before use.*

2 APPARATUS

- 2.1 Automatic tamper (compaction) device, with base plate to hold 6-in. inside diameter mold, equipped with a 10 ± 0.02 lb. rammer, and an adjustable height of fall. Includes the following.
- 2.1.1 Rammer, with a striking face that conforms to a $43 \pm 2^\circ$ segment of a 2.9 ± 0.1 in. radius circle.
- 2.1.2 Rigid foundation, to bolt the base plate of the compaction device to, such as a concrete block or rigid stand or table, with a weight greater than 200 lb.
- 2.2 Balance, Class G2 in accordance with [Tex-901-K](#), with a minimum capacity of 35 lb. readable to the nearest 0.0002 lb. (0.1g).

- 2.3 *Compaction mold kit*, includes a metal mold with a 6 in., +1/16, or -1/64 in. I.D. and 8.5 ± 1/16 in. height, base plate, hold down ring, and a collar.
- 2.4 *Measuring Assembly*, to measure the height of molded specimens. Includes the following.
- 2.4.1 *Gauge blocks*, 1, 4, 6, and 11 in. with a tolerance of ± 0.001 in.
- 2.4.2 *Indicator*, dial or digital micrometer indicator with 2 in. travel.
- 2.4.3 *Rigid stand*, with a solid level base and stable vertical post, capable of holding the dial or digital indicator above molded specimen and able to be adjusted to increase and decrease height.
- 2.5 *Metal pans with lids*, used for mixing and drying of material.
- 2.6 *Miscellaneous tools*, bristle brush, level, plastic mallet, and spatula.
- 2.7 *Mixing tool, scoop, spoon, or trowel*.
- 2.8 *Non-absorptive bowls with lids*, used to hold aggregate retained on the 7/8 in. sieve.
- 2.9 *Porous stones*, circular, with a diameter less than 6 in. and a height of 2 in.
- 2.10 *Paper discs*, non-porous with a diameter of 6 in. to fit inside the compaction mold.
- 2.11 *Oven*, capable of maintaining a temperature of 230 ± 9°F.
- 2.12 *Sample extruder*, hydraulic, automatic or manual to safely extrude a compacted specimen from the mold with no damage.
- 2.13 *Sieves*, circular with square, wire cloth openings meeting the requirements of [Tex-907-K](#).
- 2.14 *Slide hammer finishing tool and pedestal*, hammer is built with a drop weight that moves along a vertical, fixed shaft meeting the dimensions and tolerances shown in Figure 1. The hammer shown in the figure may not be representative of what may be commercially available.
- 2.15 *Soil Compactor Analyzer (SCA)*, includes a sensor rod assembly, data acquisition system, and software that stops compaction when the required energy has been delivered to the compacted lift.
- 2.15.1 SCA reference guide is available online at the following link
<https://www.txdot.gov/business/resources/materials.html>.
- 2.16 *Sprinkling jar*.
- 2.17 *Wash bottle*.

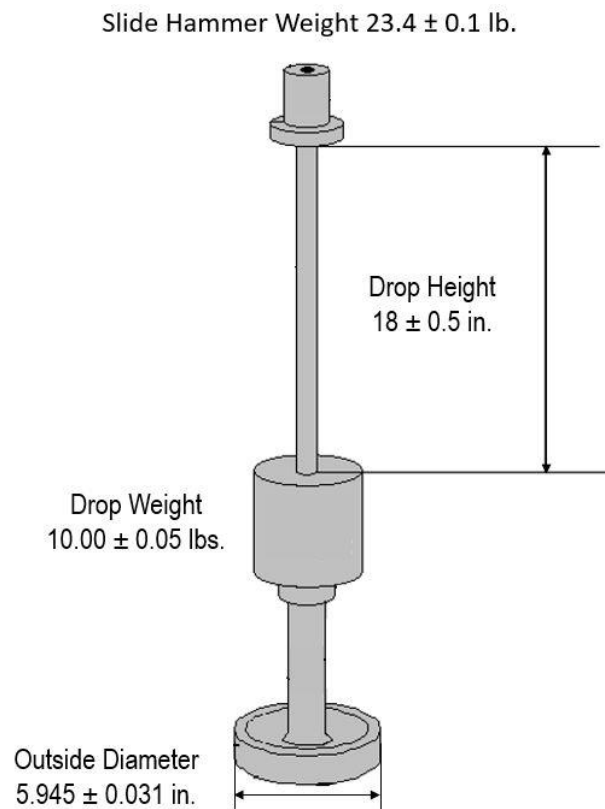

Figure 1
Slide Finishing Hammer

3 MAINTENANCE OF AUTOMATIC TAMPER (COMPACTOR)

- 3.1 Wipe the guide rods and disc with a wet rag after each use.
- 3.2 Wipe the guide rods and disc with alcohol weekly to ensure no oil or residue begins to build up on them.
- 3.3 Lubricate the guide disc before compaction with graphite. The rods will become lubricated by picking up a bit of the graphite from the edge of the disc during compaction.
- 3.4 Check the guide rod brackets weekly. There should be very little to no play between the rods and the brackets. If the play is excessive, **adjust or** replace the brackets.
- 3.5 Inspect the grabber assembly, belts, cables, height adjuster and rod and all other compactor parts for excessive wear. Replace or repair the necessary parts as needed.
- 3.5.1 The grabber assembly should be replaced as a whole because the individual parts of the assembly wear together but not uniformly.

4 SAMPLING

- 4.1 Sample material in accordance with [Tex-100-E](#).

- 4.1.1 Sample coarse-grained materials with particles larger than 7/8 in. such as embankment (soil) or non-select retaining wall backfill in accordance with Section 3 of [Tex-100-E](#).
- 4.1.2 Sample flexible base or select retaining wall backfill from stockpiles in accordance with Section 4 of [Tex-100-E](#).
- 4.1.3 When sampling flexible base to approve a stockpile as required in Item 247, "Flexible Base," prepare the sampled material in accordance with Section 6 of [Tex-100-E](#).
- 4.1.4 Sample from the roadway for reclamation (road-mixed) and treatment in accordance with Section 3 of [Tex-100-E](#).
-

5 PREPARING SAMPLE

- 5.1 Prepare the material after sampling in accordance with [Tex-101-E](#), Part II to determine a bulk gradation.
- 5.2 Estimate the weight of dry material to fill a mold to produce a compacted specimen with a height of 8 ± 0.250 in.
- 5.3 Use the bulk gradation from Section 5.1 and determine the weight of material retained on each sieve. Use the equation from Section 8.1 to calculate the weight of material retained on each sieve. Alternatively, use the equation from Section 8.2 to determine the weight on each sieve cumulatively.
- 5.4 Determine the tare weight of a mixing pan to the nearest 0.001 lbs. This will be used in Section 6.3.
- 5.5 Weigh a trial sample in the mixing pan from Section 5.4 with each size of material to the nearest 0.1 lb. (5 g) to the estimated weight from Section 5.2.
- 5.5.1 Do not use aggregate larger than 1-3/4 in.
- 5.5.2 When material contains aggregate retained on the 1-3/4 in. sieve, replace this amount of aggregate with the same amount of aggregate from passing the 1-3/4 in. and retained on the 1-1/4 in. sieve.
- 5.5.3 Material may be weighed based on the individual or cumulative weights.
- 5.6 Estimate a percent moisture at optimum and calculate the weight of water using equation from Section 8.3 to add based on the mass of the total dry weight.
- 5.6.1 The plastic limit of the material may be used as an estimated moisture content.
- 5.6.2 When electing to not compact a trial sample, weigh a minimum of four samples to produce the moisture-density curve. Estimate a percent moisture at optimum and start the curve at 2% below this estimate. Increase the percent moisture from this percent by 1% for each additional sample.
- 5.6.3 The difference in the moisture contents between the samples to produce the moisture-density curve cannot exceed 1%.
- 5.6.4 Calculate the weight of water at each percent moisture using equation from Section 8.3 to add to each sample based on the mass of the total dry weight.
- 5.6.5 The moisture-density curve must have results from at least two moisture contents below and two greater than the optimum moisture content.

- 5.7 Add the weight of water calculated from Section 5.6 into a tared sprinkling jar.
- 5.8 Add water from the sprinkling jar in increments of approximately 1/3 to the sample in the mixing pan weighed from Section 5.4.
- 5.9 After adding water, mix the sample thoroughly breaking up any lumps of material. Do not excessively mix the material that may break aggregate particles in the sample. Scrape all material off the mixing tool into the pan.
- 5.10 Weigh the wet sample and pan without the lid and record the weight to the nearest 0.001 lb.
- 5.11 Cover the mixture with a non-absorptive lid to prevent moisture evaporation and allow the trial sample to stand for a minimum of 2 hr. before compaction.
- 5.11.1 Only the trial sample may be allowed to stand undisturbed for a minimum of 2 hr. before compaction. The 2-hr. trial sample cannot be used for the moisture-density curve.
- 5.11.2 When the sample will be used to produce the moisture-density curve, it must be allowed to stand undisturbed for 18–24 hr. before compaction.
- 5.12 After the required number of hours from Section 5.11, weigh the sample and pan without the lid to the nearest 0.001 lb. Replace evaporated water to the weight from Section 5.10, and thoroughly mix to ensure even distribution of water throughout the sample. Scrape material off mixing tool and into the pan.
- 5.12.1 Water from the sprinkling jar or wash bottle may be used to rinse the mixing tool into the sample. Do not exceed the weight of the water evaporated.
- 5.13 When the sample will be used to produce the moisture-density curve, allow the sample to stand an additional 1 – 2 hr. before compaction. Do not exceed 2 hr. This is not required for the 2-hr. trial sample from Section 5.11.
- 5.14 Cover and proceed to Section 6 to compact the sample.
- 5.15 The entire sample must be used to compact the molded specimen. Do not discard any amount of material.
-

6 PROCEDURE

- 6.1 Weigh a clean compaction mold and record this weight to the nearest 0.001 lb.
- 6.2 Place one non-porous paper disc in the bottom of the mold.
- 6.3 Determine the weight of material for each lift by subtracting the tare weight of the pan from Section 5.4 from the weight recorded in Section 5.12. Divide this weight by four.
- 6.4 Sieve the sample by hand over a 7/8 in. sieve.
- 6.5 Distribute the material retained on the 7/8 in. sieve equally, based on size, shape, and number of particles, into four separate non-absorptive bowls.
- 6.5.1 Cover each bowl to prevent loss of moisture.
- 6.5.2 Using a bristle brush, brush the material stuck to the 7/8 in. sieve back into the pan containing the material passing the 7/8 in. sieve.

- 6.5.3 Divide the material passing the 7/8 in. sieve into four equal portions.
- 6.6 Weigh one of the portions of material retained on the 7/8 in. sieve with one of the portions of material passing the 7/8 in. sieve, adjusting the amount of material as needed to attain the estimated **calculated** weight for one lift from Section 6.3.
- 6.6.1 The entire sample must be used to compact a mold. Do not discard any amount of material.
- 6.7 Cover the bottom of the mold with approximately 1/4 in. of material passing the 7/8 in. sieve and level with a spatula.
- 6.8 Hand place all of the aggregate particles retained on the 7/8 in. sieve that are contained in one of the non-absorptive containers, minimizing contact with the edges of the mold.
- 6.9 Place aggregates in their most stable position. Aggregates may be placed on top of each other to make them all fit, but they must also fill the entire diameter of the mold.
- 6.10 Use a scoop held slightly above the top of the mold to pour the remaining weighed portion of material passing the 7/8 in. sieve into the mold.
- 6.11 Use a spatula to move the material passing the 7/8 in. sieve around to fill voids **and completely cover** the aggregate particles retained on the 7/8 in. sieve. Do not rearrange the aggregate particles retained on the 7/8 in. sieve.
- 6.12 Use a spatula to spade around the inside perimeter of the mold to allow some of the material passing the 7/8 in. sieve to fill cavities around the edge.
- 6.13 Level the surface with the spatula. Do not push this layer down by hand or other means than those described above.
- 6.14 Lower the hammer and allow it to rest on the surface of the uncompacted lift.
- 6.15 Prepare the SCA for data collection **and use** the option that allows the SCA to shut the automatic tamper off when the total compacted energy of 750 ± 15 ft.-lb. is achieved for each lift. This must be achieved within **50 – 60 blows**.
- 6.16 Use the SCA to start the compactor. Compact the layer by dropping the 10-lb. rammer from a height of $18 \pm 1/2$ in.
- 6.16.1 When the number of blows is not within 50 – 60, discard the sample and make any necessary adjustments to the compactor or maintenance as recommended in Section 3 to achieve 750 ± 15 ft.-lb. within this allowable range of number of blows.
- 6.17 **After compaction of the first lift, raise the hammer and remove** material sticking to the ram face and **add it** to the material in the mold.
- 6.18 Use a spatula to scarify the surface of the lift just compacted. Do not dislodge aggregates from the previously compacted lift.
- 6.19 Repeat Sections 6.6 – 6.18 to compact the **second and third lift**.
- 6.20 Compact the fourth lift. Before adding the sample into the mold, use a flexible collar to extend the height of the mold collar to prevent any loss of material. Loss of material will change the mold height and moisture content. This will not produce an accurate moisture-density curve.

- 6.21 Ensure to use all the material to mold the sample. The surface of the fourth lift must be as free as possible from large aggregates.
- 6.22 Repeat Sections 6.6 – 6.16 to compact the fourth lift.
- 6.23 After the fourth lift has been compacted, fasten the mold and base plate to a finishing pedestal ensuring it is level.
- 6.24 Use a spatula or other suitable hand tool to dislodge material from the side of the mold that extends above the compacted surface. Lightly press this material into the surface.
- 6.24.1 Do not trim the compacted material with a straightedge. The compacted material will not completely fill the mold after compaction.
- 6.25 Use a small level to check the levelness of the specimen's surface.
- 6.25.1 Level the surface by placing the slide hammer on top of the specimen's surface and tap the bottom edge of the slide hammer with the plastic mallet. Repeat until the top of the specimen is level.
- 6.25.2 After the surface is level, apply ten blows to the top of the specimen with the slide hammer by slowly raising the weight to the drop height with minimal contact with the handle.
- 6.25.3 Ensure that the shaft of the slide hammer is maintained perpendicular to the specimen surface when dropping the 10 lb. weight.
- 6.26 Repeat Section 6.25.
- 6.27 Use a small level to check the levelness of the specimen's surface and tap the edge of the slide hammer if needed to level the sample one final time.
- 6.28 Remove the mold and base plate from the finishing pedestal.
- 6.29 Weigh the specimen in the mold to the nearest 0.001 lb. and measure the sample height with the micrometer dial assembly to the nearest 0.001 in. The height of the finished specimen is required to be 8 ± 0.250 in.
- 6.30 When the height does not meet this requirement, discard the molded sample and do not use this for the moisture-density curve. An additional sample is required to be weighed and compacted to replace it.
- 6.30.1 Use the equation in Section 8.5 to adjust the sample weight to achieve the required height and repeat Section 5.2 – Section 6.30 to compact a new sample.
- 6.31 Weigh and record the tare weight of a drying pan to the nearest 0.001 lb.
- 6.32 When the height meets the requirement, place the mold in the hydraulic press and extrude the specimen from the mold.
- 6.33 Place the extruded specimen in a drying pan and break it up without losing material. Place an identification tag with the loose material.
- 6.33.1 Loss of any material may result in calculation errors for the percent moisture content and the dry and wet densities.
- 6.34 Place the drying pan with the wet material in an oven at 230°F and dry to constant weight.

- 6.34.1 Constant weight is achieved when the weight loss is less than 0.1% of the sample weight after 4 hr. of drying.
- 6.35 Remove the drying pan with the oven dried material from the oven and allow to cool for a minimum of one hour.
- 6.36 Weigh the drying pan with the oven dried material. Subtract the tare weight from Section 6.31 to calculate the weight of the oven dried material.
- 6.37 Record to the nearest 0.001 lb.
- 6.38 Do not reuse material from compacted samples for the preparation of other compaction samples.
- 6.39 Repeat this procedure to compact each of the remaining samples.
-

7 MOISTURE-DENSITY CURVE

- 7.1 Calculate the wet density and percent moisture content for each mold using the equation from Section 8.5 and 8.6.
- 7.2 Use these results and the equation in Section 8.7 to calculate the dry density for each mold.
- 7.3 Graph the dry densities on the x-axis and the percent moisture contents on the y-axis, as shown in Figure 2.
- 7.3.1 The moisture-density curve must have results with two points below and two above the optimum moisture content.
- 7.3.2 Additional samples at different moisture contents will need to be molded until this is achieved.
- 7.4 Add a second order polynomial trendline to the data points.
- 7.5 Determine the R-square value for the fit of the data to the curve. The R-square must be greater than or equal to 0.9500.
- 7.6 When the R-square is not greater than 0.9500, mold additional samples to improve the fit of the data to the curve to achieve the minimum R-square value.
- 7.7 Verify the results from the molds with moisture contents that are the furthest away from the trendline. If the results are deemed accurate, mold additional samples at different moisture contents.

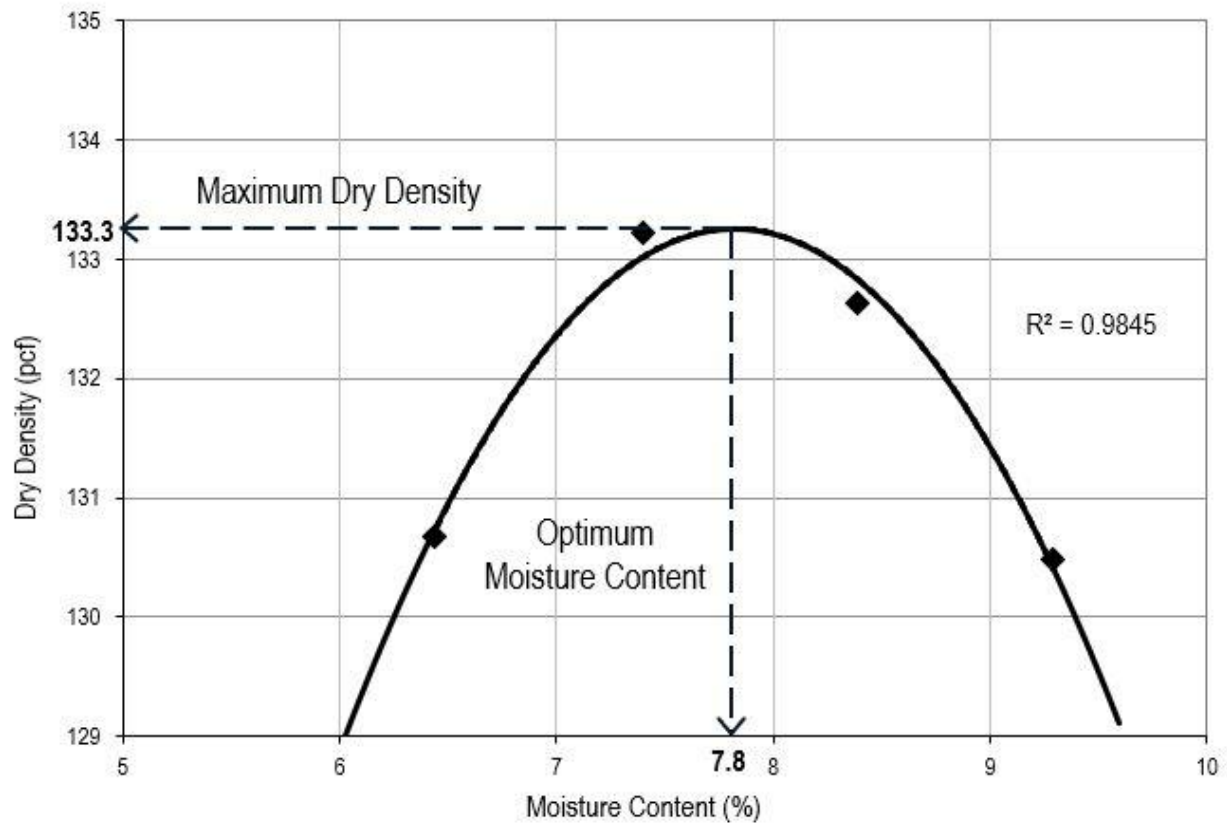

Figure 2
Example of a Moisture-Density Curve

8 CALCULATIONS

8.1 Use the following equation to calculate the individual weight retained on each sieve.

$$\text{Individual Weight Retained} = \left(\frac{\text{Individual \% Retained}}{100} \right) \times \text{Total Dry Weight}$$

8.2 Use the following equation to calculate the cumulative weight retained on each sieve.

$$\text{Cumulative Weight Retained} = \left(\frac{\text{Cumulative \% Retained}}{100} \right) \times \text{Total Dry Weight}$$

8.3 Use the following equation to calculate the weight of water to add to the sample.

$$\text{Weight of Water} = \left(\frac{\text{Moisture Content}}{100} \right) \times \text{Total Dry Weight}$$

8.4 Use the following equation to correct the weight of the sample to the required compacted mold height of 8 ± 0.250 in.

$$\text{Corrected Weight} = 8.000 \times \left(\frac{\text{Sample Weight}}{\text{Sample Height}} \right)$$

- 8.5 Use the following equation to calculate the Wet Density of the compacted mold.

$$\text{Wet Density} = \frac{W_T - W_M}{V_M}$$

Where:

W_T = weight of the mold and the compacted sample from Section 6.29.

W_M = weight of the mold.

V_M = volume of the mold, ft.³ (m³).

- 8.6 Use the following equation to calculate the Percent Moisture Content of the compacted mold.

$$\text{Percent Moisture} = 100 \times \left(\frac{W_W - W_D}{W_D} \right)$$

Where:

W_W = wet mass of the sample, lb.

W_D = oven dried mass of the molded sample, lb.

- 8.7 Use the following equation to calculate the Dry Density of the compacted mold.

$$\text{Dry Density} = 100 \times \left(\frac{\text{Wet Density}}{100 + \text{Percent Moisture}} \right)$$

Where:

Wet Density calculated from Section 8.5.

Percent Moisture calculated from Section 8.6.

9 REPORTING TEST RESULTS

- 9.1 Report the maximum dry density to the nearest 0.1 lb./ft.³.
- 9.2 Report the optimum moisture content to the nearest 0.1%.
- 9.3 Record the SCA data for the total energy, average drop height, average energy per blow, and the number of blows per lift for each compacted lift.

10 ARCHIVED VERSIONS

- 10.1 Archived versions are available.

Test Procedure for

LABORATORY COMPACTION CHARACTERISTICS AND MOISTURE-DENSITY RELATIONSHIP OF SUBGRADE, EMBANKMENT SOILS, AND BACKFILL MATERIAL



TxDOT Designation: **Tex-114-E**

Effective Date: February 2011

1. SCOPE

- 1.1 Use this test method to determine the relationship between water content and the dry unit mass (density) of sub-grade and embankment materials.
 - 1.1.1 Part I is a subgrade or embankment sample, 4 in. (101.6 mm) in diameter and 6 in. (152.4 mm) high, is molded in four layers, using a 5.5 lb. (2.5 kg) hammer dropped 25 times per layer from a height of 12 in. (304.8 mm). This part is intended for plastic and fine-grain soils, such as silts and clays (ML, MH, CL, and CH classifications as determined by Tex-142-E.)
 - 1.1.2 Part II is a subgrade or embankment sample, 6 in. (152.4 mm) in diameter and 8 in. (203.2 mm) high, is molded in four layers using a 5.5 lb. (2.5 kg) hammer dropped 75 times per layer from a height of 12 in. (304.8 mm). This part is intended for plastic, and coarse-grain soils, such as sands and gravels with fines (GM, GC, SM, and SC classifications as determined by Tex-142-E.)
 - 1.1.3 Part III is a cohesionless backfill (sand/silt) sample, 4 in. (101.6 mm) in diameter and 6 in. (152.4 mm) in height, is molded in four layers, using a 10 lb. (4.54 kg) hammer dropped 61 times per layer from a height of 12 in. (304.8 mm). Perform the test in Part III on prepared materials passing the 1/4 in. (6.3 mm) sieve. This part is intended for clean, cohesionless sands used for MSE backfill (SW and SP classifications as determined by Tex-142-E.)
- 1.2 Follow Tex-113-E to determine moisture-density relationships of flexible base materials, coarse-grained materials containing particles larger than 7/8 in. (22.4 mm), and treated subgrade and embankment materials. Use of the Soil Compactor Analyzer (SCA) is required at this time for flexible base materials only.
- 1.3 The values given in parentheses (if provided) are not standard and may not be exact mathematical conversions. Use each system of units separately. Combining values from the two systems may result in nonconformance with the standard.

2. DEFINITIONS

- 2.1 *Maximum Dry Density* (D_a)—Maximum dry density is the maximum value obtained by the compaction curve using the specified compactive effort.
- 2.2 *Optimum Water Content* (W_{opt})—Optimum water content is the water content at which the soil can be compacted to the D_a .
- 2.3 *Compactive Effort* (C.E.)—Compactive effort is the total energy, expressed as foot-pounds per cubic inch (kilo-Newton-meters per cubic meter) used to compact the specimen.

- C.E. is calculated as follows:

$$\frac{Ht. \text{ of Drop (ft or m)} \times Wt. \text{ of Hammer (kN or lb)} \times \# \text{ Drops} \times \# \text{ Layers}}{\text{Volume of Mold (m}^3 \text{ or in}^3)}$$

- This procedure requires, for Part I and Part II, 7.30 ft.-lb./in.³ (604 kN-m/m³) and, for Part III, 32.36 ft.-lb./in.³ (2677 kN-m/m³), equivalent to ASTM D 1557.

3. APPARATUS

- 3.1 *Automatic tamper (compaction) device*, with:
- Base plate to hold 4 in. (101.6 mm) or 6 in. (152.4 mm) inside diameter (ID) forming molds
 - 5.5 ± 0.02 lb. (2.5 ± 0.01 kg) sector-face rammer
 - 10 ± 0.02 lb. (4.55 ± 0.01 kg) sector-face rammer
 - Adjustable drop height
 - Striking face of the rammer conforming to a 43 ± 2° segment of a 2.9 ± 0.1 in. (74 ± 2.5 mm) radius circle
 - Rigid foundation, such as a concrete block, with a mass of not less than 200 lb. (91 kg) on which the base plate of the tamper is secured. (An alternate foundation support, such as a rigid stand or table, is allowed if the D_a produced is within 2% of that produced by an automatic tamper bolted to a concrete floor).
- 3.2 *Rigid metal compaction mold*, with 4 ± 1/64 in. (101.6 ± 0.4 mm) average ID and a height of 6 ± 0.0026 in. (152.4 ± 0.7 mm) with removable collar, and/or a 6 in., +1/16 or -1/64 in. (152.6 mm, +1.6 or -0.4 mm) average ID and a height of 8-1/2 ± 1/16 in. (215.9 ± 1.6 mm) with removable collar.
- 3.3 *Metal stand*, with a set of standard spacer blocks and a micrometer dial assembly, with 2 in. (50 mm) travel, for determining height of specimens. Spacer blocks 1, 4, 6, and 11 in. (25.4, 101.6, 152.4, and 279.4 mm) accurate to 0.001 in. (0.025 mm).

- 3.4 *Balance*, Class G2 in accordance with Tex-901-K, with a minimum capacity of 35 lb. (15 kg).
- 3.5 *Extra base plate*, secured on a rigid stand to hold the forming mold.
- 3.6 *Hydraulic press*, to extrude molded specimens.
- 3.7 *Drying oven*, maintained at $230 \pm 9^{\circ}\text{F}$ ($110 \pm 5^{\circ}\text{C}$).
- 3.8 *Metal pans*, wide and shallow for mixing and drying materials.
- 3.9 *Circular porous stones*, slightly less than 6 in. (152.4 mm) in diameter and 2 in. (51 mm) high.
- 3.10 *Supply of small tools*, including a 4–5 lb. (1.8–2.3 kg) rawhide hammer, level, finishing tool, and others.
- 3.11 *Standard U.S. sieves*, meeting the requirements of Tex-907-K, in the following sizes:
- 1-3/4 in. (45 mm)
 - 7/8 in. (22.4 mm)
 - 3/8 in. (9.5 mm)
 - No. 4 (4.75 mm).

4. CALIBRATING EQUIPMENT

- 4.1 Calibrate equipment in accordance with Tex-198-E. In addition, calibrate equipment before initial use, after repair, or after any occurrence that might affect the test results.
- 4.2 Follow the steps outlined in Tex-113-E, Section 4.

PART I—MEASURING MOISTURE-DENSITY RELATIONSHIP OF SUBGRADE AND EMBANKMENT SOILS

5. SCOPE

- 5.1 Part I uses a 4-in. (102 mm) ID mold and applies only to soils with:
- 100% passing the 3/8 in. (9.5 mm) sieve
 - $\geq 80\%$ passing the 1/4 in. (6.3 mm) sieve
 - ML, MH, CL, and CH soil classification as determined by Tex-142-E.

6. PREPARING SAMPLE

- 6.1 Prepare the material in accordance with Tex-101-E, Part II. Do not use materials that have been previously laboratory compacted.
-

7. PROCEDURE

- 7.1 Determine the percent hygroscopic moisture of a representative sample of prepared material in accordance with Tex-103-E.
- 7.2 Separate sample on 7/8 in. (22.4 mm), 3/8 in. (9.5 mm), and 1/4 in. (6.3 mm) sieves and determine particle size distribution.
- 7.3 Estimate the mass of air-dried material that will fill the mold when wetted and compacted.
- 7.4 Using this estimated mass, and the percentages of the various sizes of particles obtained in Section 7.2, compute the cumulative masses of each size to combine to make a specimen.
- 7.5 Using the masses calculated in Section 7.3, recombine at least four specimens of approximately 7.7 lb. (3.5 kg) each.
- 7.6 Estimate the optimum percent moisture required to attain maximum density.
Note 1—The plastic limit is a good indicator of optimum moisture content, typically within 2%, or 3–4% higher for $PI > 35$ material.
- 7.7 Start the M-D curve using a sample with a moisture content of 2% below the estimated optimum moisture content. For soils with a low to moderate plasticity index ($PI < 35$), adjust the moisture content of the remaining samples in approximately 2% increments to attain two samples above and two samples below the optimum moisture content. For soils with high plasticity index ($PI \geq 35$), the moisture content may be adjusted in 4% increments to attain two samples above and two samples below the optimum moisture.
Note 2—After compacting the first two or three specimens, construct the initial M-D curve to aid in evaluation of the shape of the curve. If necessary, adjust the water content of the other prepared samples by adding additional water or air-drying to obtain a well-defined compaction curve.
- 7.8 Calculate the mass of the water to be added based on the air-dry mass of the material.
- 7.9 Weigh out this amount of water into a tared sprinkling jar.
- 7.10 Sprinkle water onto the soil during mixing, in increments.
- 7.11 Thoroughly mix each specimen to ensure even distribution of water throughout specimen.

- 7.12 Cover the mixed sample and allow sample to stand and cure for at least 12 hr. before compacting. When the PI is less than 12, reduce the curing time to no less than 3 hr. Cure split or referee samples for the full 12 hr.
- 7.13 Assemble and secure the mold and collar to the base plate.
- 7.14 Thoroughly remix the cured sample.
- 7.15 Obtain approximately 1 lb. (453.6 g) of the sample and determine water content as described in Tex-103-E, Section 7.
- 7.16 Place loose soil into the mold and spread into a layer of uniform thickness.
- 7.17 Before compaction, use hand tools to tamp the soil lightly until it is not fluffy or loose.
- 7.18 Separate the material in the pan into four equal portions. Each portion must contain representative quantities of all sizes and adequate material to compact four 1.5-in. (38-mm) layers.
- 7.19 For each layer, dump the material into the mold. Spade and level the layer of material with a spatula to fill cavities around the edge and to ensure an even distribution of material in each layer before compacting. Do not push this layer down by hand or other means than that described above.
- 7.20 Compact each layer using 25 per lift with a drop height of 12 in. (304.88 mm).
- 7.21 Use the soil mass and compacted thickness of the first lift to adjust the mass and thickness of the subsequent lifts.
- 7.22 Upon completion of compacting each of the first three lifts, use a knife or other convenient tool to scarify the surface to a depth of 1/4 in. (6.3 mm). Dislodge uncompacted soils that extend above the compacted surface.
- 7.23 Upon completion of the fourth lift, the compacted specimen should extend above the top, but by no more than 1/4 in. (6.3 mm). Discard the compacted specimen if it does not extend above the top of the mold at any point.
- 7.24 After compaction of the last lift, remove the collar and use a straight edge or draw knife to carefully trim the compacted specimen even with the top of the mold.
- 7.25 Invert the mold and trim the bottom of the specimen even with the bottom of the mold.
- 7.26 Use trimmed soil from the specimen to fill holes on the trimmed surfaces. Trim again as needed to ensure a smooth, level surface.
- 7.27 Determine and record the mass of the specimen and mold as W_T to the nearest 0.001 lb. (0.5 g) under Tex-113-E, Section 9.
- 7.28 Record the data on [Form 113.4](#), "Moisture Density Relations of Base Material and Sand or Subgrade and Embankment Soils."

- 7.29 Use the hydraulic jack press to remove the specimen from the mold.
- 7.30 Place the compacted specimen and identification tag into a large pan and break into several pieces.
- 7.31 Obtain the mass of the drying pan and wet sample and record to 0.001 lb. (0.5 g).
- 7.32 Place the specimen in an oven at a temperature of $230 \pm 9^\circ\text{F}$ ($110 \pm 5^\circ\text{C}$) and dry to constant weight.
Note 3—Use a $140 \pm 9^\circ\text{F}$ ($60 \pm 5^\circ\text{C}$) oven for ML or MH soils (as determined by Tex-145-E).
- 7.33 Record the mass of the oven-dried material to the nearest 0.001 lb. (0.5 g) under Tex-113-E, Section 9.
- 7.34 Repeat Sections 7.8–7.33 for all samples.
-

8. CALCULATIONS

- 8.1 Use the equations in Tex-113-E, Section 9.
-

9. GRAPHS

- 9.1 Plot the molding moisture and dry density curve for D_a as shown in Figure 1.

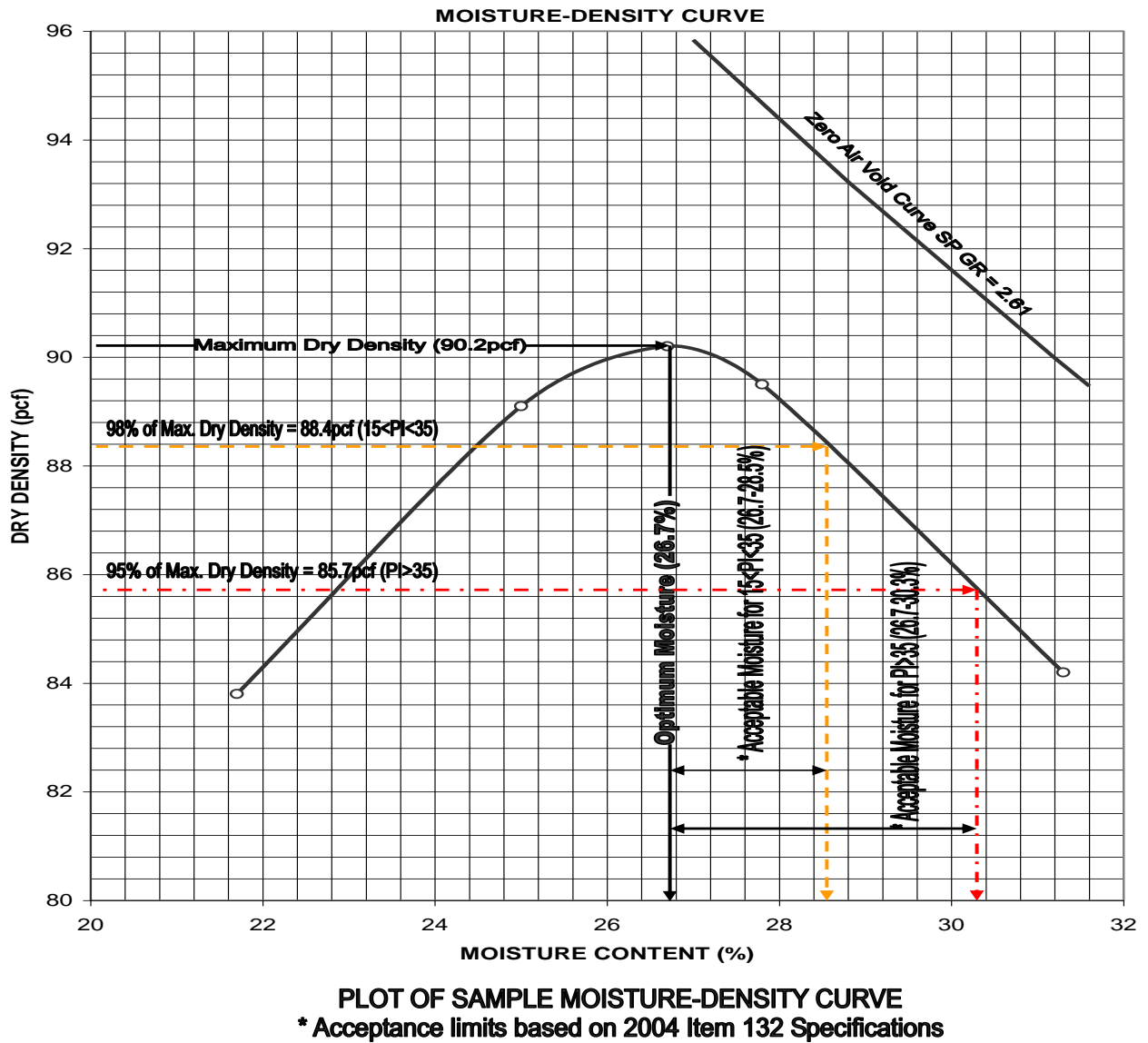

Figure 1—Plot of Sample Moisture-Density Curve

10. REPORTING TEST RESULTS

10.1 Report:

- D_a to the nearest 0.1 lbs/ft³ (1 kg/m³)
- W_{opt} to the nearest 0.1 %.

PART II—MEASURING MOISTURE-DENSITY RELATIONSHIP OF SUBGRADE AND EMBANKMENT SOILS

11. SCOPE

- 11.1 Part II uses a 6-in. (152.4-mm) diameter mold and applies only to soils with:
- 100% passing the 7/8-in. (22.4-mm) sieve
 - $\leq 20\%$ passing the 1/4-in. (6.3-mm) sieve
 - GM, GC, SM, or SC soil classifications as described by Tex-142-E
- 11.2 Use Tex-113-E for moisture-density curve determination of flexible base materials and coarse-grained materials containing particles larger than 7/8 in. (22.4 mm). Use of the Soil Compactor Analyzer (SCA) is required at this time for flexible base materials only.
-

12. PREPARING SAMPLE

- 12.1 Secure a representative sample of material and prepare approximately 132 lb. (60 kg) of moist soil as described in Tex-101-E, Part II for moisture-density test. Do not reuse soil that has been previously laboratory compacted.
-

13. PROCEDURE

- 13.1 Determine the percent hygroscopic moisture of a representative sample of prepared material in accordance with Tex-103-E.
- 13.2 Separate sample on 7/8 in. (22.4 mm), 3/8 in. (9.5 mm), and 1/4 in. (6.3 mm) sieves, and determine the particle size distribution.
- 13.3 Estimate the mass of air-dried material that will fill the mold when wetted and compacted.
- 13.4 Using this estimated mass and the percentages of the various sizes of particles obtained in Section 13.2, compute the cumulative masses of each size to combine to make a specimen.
- 13.5 Using the masses calculated in Section 13.3, recombine at least four specimens of approximately 22 lb. (10 kg) each.
- 13.6 Estimate the optimum percent moisture required to attain maximum density.
Note 4—The plastic limit is a good indicator of optimum moisture content, typically within 2%, or 3–4% higher for PI >35 material.
- 13.7 Start the M-D curve using a sample with a moisture content of 2% below the estimated optimum moisture content. For soils with a low to moderate plasticity index (PI < 35), adjust the moisture content of the remaining samples in approximately 2% increments to
-

attain two samples above and two samples below the optimum moisture content. For soils with high plasticity index ($PI \geq 35$), adjust the moisture content in 4% increments to attain two samples above and two samples below the optimum moisture.

Note 5—After compacting the first two or three specimens, the initial M-D curve can be constructed to aid in evaluation of the shape of the curve. If necessary, adjust the water content of the other prepared samples by adding additional water or air-drying to obtain a well-defined compaction curve.

- 13.8 Calculate the mass of the water to be added based on the air-dry mass of the material.
- 13.9 Weigh the required mass of water into a tared sprinkling jar.
- 13.10 Sprinkle water onto the soil during mixing, in increments.
- 13.11 Thoroughly mix each specimen to ensure an even distribution of water.
- 13.12 Cover the mixed sample and allow sample to stand and cure for at least 12 hr. before compacting. When the PI is less than 12, reduce the curing time to not less than 3 hr. Cure split or referee samples for the full 12 hr.
- 13.13 Assemble and secure the mold and collar to the base plate.
- 13.14 Thoroughly remix the cured sample.
- 13.15 Obtain approximately 1 lb. (453.6 kg) of the sample and determine water content as described in Tex-103-E, Section 7.
- 13.16 Place loose soil into the mold and spread into a layer of uniform thickness.
- 13.17 Use hand tools to tamp the soil lightly until it is not fluffy or loose.
- 13.18 Separate the material in the pan into four equal portions. Each portion must contain representative quantities of all sizes and adequate material to compact four 2-in. (50-mm) layers.
- 13.19 For each layer, dump the material into the mold. Spade and level the layer of material with a spatula to fill cavities around the edge and to ensure an even distribution of material in each layer before compacting. Do not push this layer down by hand or other means than that described above.
- 13.20 Compact each layer using 75 per lift with a drop height of 12 in. (304.88 mm).
- 13.21 Use the soil mass and compacted thickness of the first lift to adjust the mass and thickness of the subsequent lifts.
- 13.22 Upon completion of compacting each of the first three lifts, use a knife or other convenient tool to scarify the surface and dislodge the uncompacted soils that extend above the compacted surface.

- 13.23 Use the finishing tools outlined in Tex-113-E and four medium-firm blows of the 4–5 lb. (1.818–2.273 kg) rawhide hammer to level and finish the fourth lift.
- 13.24 Using the height-measuring stand, measure and record the specimen height to the nearest 0.001 in. (0.025 mm). The height of the finished specimen should be $8 \pm 1/4$ in. (2036.3 mm). Discard the specimen if it is too short or too tall.
Note 6—To adjust the molded height of specimen in Section 13.21, calculate as follows:
Dry Weight of Specimen = (Dry Weight of Specimen \times 8") / Height of Specimen
- 13.25 Determine and record the mass of the specimen and mold as W_T to the nearest 0.001 lb. (0.5 g), under Tex-113-E, Section 9.
- 13.26 Record the data on [Form 113.4](#).
- 13.27 Use the hydraulic jack press to remove the specimen from the mold.
- 13.28 Place the compacted specimen and identification tag into a large pan and break into several pieces.
- 13.29 Obtain the mass of the drying pan and wet sample and record to 0.001 lb. (0.5 g).
- 13.30 Place the specimen in an oven at a temperature of $230 \pm 9^\circ\text{F}$ ($110 \pm 5^\circ\text{C}$) and dry to constant weight.
Note 7—Use a $140 \pm 9^\circ\text{F}$ ($60 \pm 5^\circ\text{C}$) oven for ML or MH soils (as determined by Tex-142-E) or soils with measurable sulfates (as determined by Tex-145-E).
- 13.31 Record the mass of the oven-dried material to the nearest 0.001 lb. (0.5 g) under Tex-113-E, Section 9.
- 13.32 Repeat Sections 13.8–13.31 for all samples.

14. CALCULATIONS

- 14.1 Use the equations under Tex-113-E, Section 9.

15. GRAPHS

- 15.1 Plot the molding moisture vs. the dry density curve for D_a shown in Figure 1.

16. REPORTING TEST RESULTS

- 16.1 Report test results as described in Part I.

PART III—MEASURING MOISTURE-DENSITY RELATIONSHIP OF COHESIONLESS BACKFILL

17. SCOPE

17.1 Part III uses a 4-in. (102-mm) ID mold and applies only to cohesionless soils and backfills as described below:

- 100% passing the 1/4 in. (9.5-mm) sieve
- $\geq 50\%$ passing the No. 4 (4.75-mm) sieve
- $\leq 25\%$ passing the No. 200 (75-mm) sieve
- SW – SP classification.

18. PREPARING SAMPLES

18.1 Prepare the material in accordance with Tex-101-E, Part II.

19. PROCEDURE

19.1 Perform Part I, Sections 7.1–7.15, except for Section 7.12.

19.2 Mix the material thoroughly and separate into four equal portions. Each portion must contain representative quantities of all sizes and contain enough material to compact four 1.5-in. (38-mm) layers.

19.3 For each layer, dump the material into the mold. Spade and level the layer of material with a spatula to fill cavities around the edge and to ensure an even distribution of material in each layer before compacting. Do not push this layer down by hand or other means than that described above.

19.4 Compact each layer by applying 61 ram blows with a 10 lb. (4.55 kg.) rammer from a height of 12 in. (457.2 mm).

19.5 Stop the compactor as frequently as necessary to clean the ram face.

19.6 Use the soil mass and compacted thickness of the first layer to adjust the mass and thickness of the subsequent layers.

19.7 Each layer thickness should be approximately equal in height and mass. All material should be molded.

19.8 Upon completion of the fourth lift, the compacted specimen should extend above the top, but by no more than 1/4 in. (6.3 mm). Discard the compacted specimen if it does not extend above the top of the mold at any point.

- 19.9 Remove the collar and use a straight edge or draw knife to carefully trim the compacted specimen even with the top of the mold.
- 19.10 Use trimmed material from the specimen to fill holes on the trimmed surfaces. Trim again, as needed to ensure a smooth, level surface.
- 19.11 Determine and record the mass of the specimen and mold as W_T to the nearest 0.001 lb. (0.5 g) under Tex-113-E, Section 9.
- 19.12 Record the data on [Form 113.4](#).
- 19.13 Carefully center the specimen over a porous stone and place in the hydraulic press to extrude the specimen from the mold.
- 19.14 Place the compacted specimen and identification tag into a large pan and break into several pieces.
- 19.15 Obtain the mass of the drying pan and wet sample and record to 0.001 lb. (0.5 g).
- 19.16 Place the drying pan with wet material in an oven at a temperature of 230°F (110°C) and dry to constant weight.
- 19.17 Record the mass of the oven-dried material to the nearest 0.001 lb. (0.5 g) under Tex-113-E, Section 9.
- 19.18 Repeat Sections 19.2–19.17 for all samples.
- Note 8**—After compacting the first two or three specimens, the initial M-D curve can be constructed to aid in evaluation of the shape of the curve. If necessary, adjust the water content of the other prepared samples by adding additional water or air-drying to obtain a well-defined compaction curve.

20. CALCULATIONS

- 20.1 Use the equations under Tex-113-E, Section 9.

21. REPORTING TEST RESULTS

- 21.1 Report test results as described in Part I.

22. FAMILY OF CURVES

- 22.1 The materials used for subgrade and embankment construction are variable in color, texture, and moisture-density relationship.
- 22.2 To adequately control the compaction and field densities of these materials, it is necessary to have several compaction curves prepared and plotted on the same graph to

assist the inspector to make a sound judgment as to which curve is representative of the material being tested for field density.

- 22.3 The family of compaction curves shown in Figure 2 illustrates that, as the material's plasticity and fineness increase, the D_a will decrease with a corresponding increase in W_{opt} . The wet leg of the compaction curve is generally parallel with the 0% air void line.
- 22.4 To properly correlate the soil properties to a compaction curve, the soil properties presented in Table 1 should be provided along with the family of compaction curves.

Table 1—Soil Properties, Family of Curves, & One-Point Control

Curve No.	Max. Dry Density kg/m ³ (pcf)	Optimum Water Content %	Liquid Limit %	PI	Wet Gradation, % Retained			Material Description
					22.4 mm (7/8 in.)	9.5 mm (3/8 in.)	4.75 mm (No.4)	
1	93.6 (1499.5)	22.0	61	43	0	0	0	dark brown clay
2	96.6 (1547.5)	20.4	48	30	0	0	1.4	brown clay
3	100.3 (1606.8)	18.8	44	27	0	0	2.5	brown clay
4	104.6 (1675.7)	17.4	38	21	0	0	4.3	lt. brown clay

23. ONE-POINT CONTROL

- 23.1 In the event the material being tested for field density does not match the description and properties of any of the materials from the family of compaction curves, the one-point control method may be used to derive an adjusted D_a and W_{opt} by:
- air drying the field sample to a water content near the plastic limit of the material
 - molding one compaction specimen
 - using the one-point moisture-density data to construct a compaction curve which mimics the shape of the family of curves
- 23.2 The wet leg of the compaction curve is well defined by the 0% air void line; therefore, it is essential to air-dry the field sample to a water content near the plastic limit of the material and provide better definition of the dry side of the curve. Figure 2 shows an example of the one-point control method.

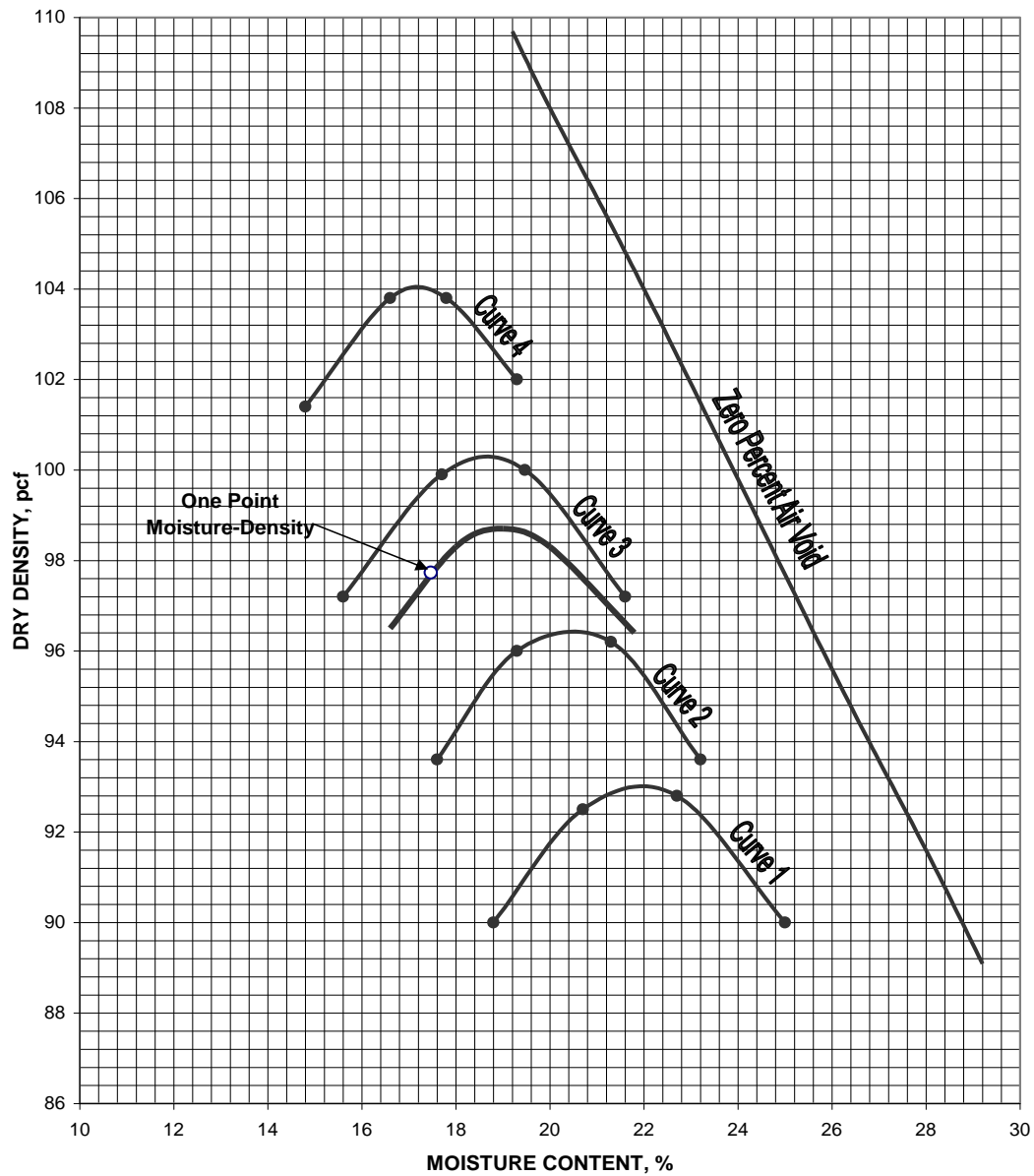

Figure 2—Family of Curves and One-Point Control (Example)

24. ARCHIVED VERSIONS

24.1 Archived versions are available.

Test Procedure for**CEMENT TREATED MATERIALS**TxDOT Designation: **Tex-120-E****Effective Date: April 2022**

1. SCOPE

- 1.1 This test method consists of two parts for the laboratory compaction of cement treated materials. Cement treated materials may include subgrade (soils), reclaimed roadway (existing materials), existing materials blended with flexible base, or flexible base only.
- 1.2 Part I is used to determine the optimum moisture content and maximum dry density (M-D) curve in accordance with [Tex-113-E](#) for cement treated materials prepared in the laboratory or sampled from the roadway after mixing. This part may also be used to verify a M-D curve with material sampled from the roadway after mixing.
- 1.2.1 Specimens are compacted using an automatic tamper (compaction) device equipped with a Soil Compactor Analyzer (SCA). All specimens are 6 in. in diameter and 8 ± 0.250 in. in height.
- 1.3 Part II is a mixture design procedure used to determine a target cement content from materials prepared in the laboratory based on the unconfined compressive strength (UCS). This part may also be used to verify the UCS of material sampled from the roadway after mixing.
- 1.3.1 The target cement content is determined from the UCS of compacted specimens after seven days of curing in an environment with a minimum humidity of 95%. The humidity may be measured using a handheld hygrometer.
- 1.3.2 Part II includes an optional moisture conditioning procedure that includes submerging compacted specimens completely in water for 24 hr. after seven days of curing.
-

2. APPARATUS

- 2.1 As outlined in test methods:
- [Tex-100-E](#);
 - [Tex-101-E](#);
 - [Tex-113-E](#);
 - [Tex-117-E](#); and
 - [Tex-400-A](#).
- 2.2 *Container*, adequate height and volume to completely submerge compacted specimens.
- 2.3 *Handheld hygrometer*.

2.4 Load cell, minimum 10K (for use with automated load frame).

3. REPORTING

3.1 Report all data and pertinent information pertinent using SiteManager form '[Tx120-21.xlsm](#)'.

3.2 This form is available from the Materials & Tests Division/Soils & Aggregates Section and online at the following link <https://www.txdot.gov/inside-txdot/forms-publications/consultants-contractors/forms/site-manager.html>.

4. MATERIAL SAMPLING AND PREPARATION

4.1 *This test procedure does not claim to address the safety concerns associated with its use. It is the responsibility of the user of this test procedure to establish the appropriate safety, health, and environmental practices and determine the applicability of regulatory limitations before use.*

4.2 Obtain a minimum of 1 gal. of cement in a sealed container from a fresh supply of an approved source from the Department's Material Producer List unless otherwise directed.

4.3 When testing materials for Part I, sample a minimum of 100 lb. in accordance with [Tex-100-E](#) for soils or [Tex-400-A](#) for flexible base and prepare in accordance with [Tex-101-E](#), Part II.

4.4 When testing materials for Part II, sample a minimum of 300 lb. in accordance with [Tex-100-E](#) for soils or [Tex-400-A](#) for flexible base and prepare in accordance with [Tex-101-E](#), Part II.

4.5 When reclaimed asphalt pavement (RAP) is included and greater than 1-3/4 in., resize the RAP to pass the 1-3/4 in. sieve.

Note 1 Heating the RAP to a maximum temperature of 140°F can assist in resizing the RAP.

4.6 When testing material from the roadway after reclamation and mixing, sample the treated material before the start of compaction.

4.6.1 Screen the cement treated material using a 7/8 in. sieve and a 1/4 in. sieve at the field moisture content, without drying.

4.6.2 Separate the material retained on the sieve from the material passing the sieve.

4.6.3 Cover the materials to retain field moisture.

PART I—MOISTURE-DENSITY CURVE

5. PROCEDURE

5.1 *This test procedure does not claim to address the safety concerns associated with its use. It is the responsibility of the user of this test procedure to establish the appropriate safety, health, and environmental practices and determine the applicability of regulatory limitations before use.*

5.2 Select a percentage of cement.

- 5.3 Determine the optimum moisture content and maximum dry density (M-D) curve for the material prepared from Article 4., "Material Sampling and Preparation," in accordance with the applicable Sections of [Tex-113-E](#).
- 5.3.1 Prior to compaction of [Tex-113-E](#), add the cement uniformly to ensure even distribution of the cement throughout the sample. The amount of cement added is a percentage based on the dry mass of the material to be treated.
- 5.4 *Using Roadway Mixed and Treated Material.*
- 5.4.1 Recombine the material from Article 4., "Material Sampling and Preparation," to produce samples for laboratory compaction.
- 5.4.2 Determine the M-D curve for this material in accordance with the applicable Sections of [Tex-113-E](#). Alternatively, compact samples to only verify a M-D curve that was produced from laboratory prepared materials in Section 5.3.
- 5.4.2.1 Estimate the field moisture content. Place material in a pan and weigh to the nearest 0.001 lb.
- 5.4.2.2 Adjust the moisture content of material by adding or removing moisture as needed. When removing moisture, do not oven dry the material. Stir frequently and as needed to achieve the necessary mass of material.
- 5.4.2.3 Determine the mass of material needed to achieve the desired moisture content.
- 5.4.2.4 Weigh material to the nearest 0.001 lb.
-

6. TEST REPORT

- 6.1 Cement Content, 0.1%;
- 6.2 Optimum Moisture Content, 0.1%; and
- 6.3 Maximum Dry Density, 0.1 pcf.
-

PART II—MIXTURE DESIGN TO DETERMINE THE TARGET CEMENT CONENT

7. PROCEDURE

- 7.1 *This test procedure does not claim to address the safety concerns associated with its use. It is the responsibility of the user of this test procedure to establish the appropriate safety, health, and environmental practices and determine the applicability of regulatory limitations before use.*
- 7.2 Determine the optimum moisture content and maximum dry density (M-D) curve using 5% cement for the material prepared from Article 4., "Material Sampling and Preparation," in accordance with the applicable Sections of [Tex-113-E](#).
- 7.2.1 Before compaction of [Tex-113-E](#), add the cement uniformly to ensure even distribution of the cement throughout the sample. The amount of cement added is a percentage based on the dry mass of the material to be treated.

- 7.3 Recombine the material prepared from Article 4., "Material Sampling and Preparation," and mold three samples at 3, 5, and 7% cement in accordance with the applicable Sections of [Tex-113-E](#) to determine the unconfined compressive strength (UCS) at each percentage. Samples may be molded at fewer, more, or different percentages of cement as deemed necessary.
- 7.3.1 Calculate the moisture content for each cement content using equation from Section 8.1 of this test procedure.
- 7.3.2 Before compaction of [Tex-113-E](#), add the cement uniformly to ensure even distribution of the cement throughout the sample. The amount of cement added is a percentage based on the dry mass of the material to be treated.
- 7.3.3 Place a card on each specimen labeling the laboratory identification number and the percent of cement.
- 7.3.4 Proceed to Section 7.5 for curing the specimens.
- 7.4 *Using Roadway Mixed and Treated Material to Verify UCS.*
- 7.4.1 Recombine the material from Article 4., "Material Sampling and Preparation," and mold three samples in accordance with the applicable Sections of [Tex-113-E](#).
- 7.4.1.1 Estimate the field moisture content. Place material in a pan and weigh to the nearest 0.001 lb.
- 7.4.1.2 Adjust the moisture content of material by adding or removing moisture as needed. When removing moisture, do not oven dry the material. Stir frequently and as needed to achieve the necessary mass of material.
- 7.4.1.3 Determine the mass of material needed to achieve the desired moisture content.
- 7.4.1.4 Weigh material to the nearest 0.001 lb.
- 7.5 *Curing.*
- 7.5.1 Store the compacted specimens the same day as molded with the top and bottom porous stones in an environment with a minimum humidity of 95% for seven days. Do not use a triaxial cell.
- 7.5.2 When the humidity is unknown, use a handheld hygrometer to measure the humidity to ensure it is a minimum of 95%.
- 7.5.3 When necessary, place a pan on top of the top porous stone to protect the specimen from any dripping water.
- 7.6 After seven days of curing, remove the test specimens from the environmental room and use a cloth to remove any free water on the surface of the specimens.
- 7.7 Weigh the specimens to the nearest 0.001 lb. and measure the sample height with the micrometer dial assembly to the nearest 0.001 in.
- 7.8 Measure the UCS in accordance with the applicable Sections of [Tex-117-E](#), Part II.
- 7.9 Determine the target cement content using the template from Article 3., "Reporting," with the UCS test results from Section 7.8.
- 7.10 *Optional Moisture Conditioning by 24-hr. Water Submersion.*

- 7.10.1 Use the M-D curve with the calculated moisture content from Sections 7.2, 7.3, or 7.4 from this procedure.
- 7.10.2 Recombine the material prepared from Article 4., "Material Sampling and Preparation," and mold three samples in accordance with the applicable Sections of Tex-113-E.
- 7.10.2.1 Prior to compaction of [Tex-113-E](#), add the cement uniformly to ensure even distribution of the cement throughout the sample. The amount of cement added is a percentage based on the dry mass of the material to be treated.
- 7.10.3 Cure the compacted specimens in accordance with Section 7.5.
- 7.10.4 Place the specimens with the bottom porous stone only, into the container identified in Section 2.2.
- 7.10.5 Fill the container to approximately 1/2 to 1 in. above the top of the specimens with tap water in a manner that does not disturb and contact the specimens.
- 7.10.6 Soak each specimen in the container for 24 hr. ± 1 hr.
- 7.10.7 Remove each specimen from the container and use an absorptive cloth or paper towel to remove free water on the surface of the specimen.
- 7.10.8 Measure the UCS in accordance with the applicable Sections of [Tex-117-E](#), Part II.

8. CALCULATIONS

- 8.1 Use the following equation to determine the percent moisture content at different cement percentages.

$$\% \text{ Moisture Content} = \% \text{ Optimum Moisture} + (0.25 \times \% \text{ Cement Difference})$$

Where:

$\% \text{ Moisture Content}$ = Moisture content of samples prepared for laboratory compaction;

$\% \text{ Optimum Moisture}$ = Optimum moisture content from the Moisture-Density curve; and

$\% \text{ Cement Difference}$ = Difference in cement content between the cement content used for the Moisture-Density curve and the chosen molding cement content.

9. TEST REPORT

- 9.1 Target Cement Content, 0.1%;
- 9.2 Optimum Moisture Content, 0.1%;
- 9.3 Maximum Dry Density, 0.1 pcf; and
- 9.4 Unconfined Compressive Strength, nearest whole psi.

Test Procedure for**LIME TREATED MATERIALS**TxDOT Designation: **Tex-121-E**Effective Date: **May 2022**

1. SCOPE

- 1.1 This test method consists of three parts for the laboratory compaction of lime treated materials. Lime treated materials may include subgrade (soils), reclaimed roadway (existing materials), existing materials blended with flexible base, or flexible base only.
- 1.2 Part I is used to determine the optimum moisture content and maximum dry density (M-D) curve in accordance with [Tex-113-E](#) for lime treated materials prepared in the laboratory or sampled from the roadway after mixing. This part may also be used to verify a M-D curve with material sampled from the roadway after mixing.
- 1.2.1 Specimens are compacted using an automatic tamper (compaction) device equipped with a Soil Compactor Analyzer (SCA). All specimens are 6 in. in diameter and 8 ± 0.250 in. in height.
- 1.3 Part II is a mixture design procedure used to determine a target lime content from materials prepared in the laboratory based on the unconfined compressive strength (UCS). This part may also be used to verify the UCS of material sampled from the roadway after mixing.
- 1.3.1 The target lime content is determined from the minimum percentage of lime to achieve a pH of 12.4 and UCS of compacted specimens after seven days of curing and ten days of capillary rise.
- 1.4 Part III determines the minimum percent lime needed for a lime treated mixture to achieve a pH of 12.4 in conjunction with [Tex-128-E](#). Cation exchange occurs at this pH where the soil particle structure will achieve improved workability and decrease in swell and plasticity.
-

2. APPARATUS

- 2.1 As outlined in test methods:
- [Tex-100-E](#);
 - [Tex-101-E](#);
 - [Tex-113-E](#);
 - [Tex-117-E](#);
 - [Tex-128-E](#); and
 - [Tex-400-A](#).

- 2.2 Load cell, minimum 10K (for use with automated load frame).
-

3. REPORTING

- 3.1 Report all data and pertinent information pertinent using SiteManager form '[Tx120-21.xlsm](#)'.
- 3.2 This form is available from the Materials & Tests Division/Soils & Aggregates Section and online at the following link <https://www.txdot.gov/inside-txdot/forms-publications/consultants-contractors/forms/site-manager.html>.
-

4. MATERIAL SAMPLING AND PREPARATION

- 4.1 *This test procedure does not claim to address the safety concerns associated with its use. It is the responsibility of the user of this test procedure to establish the appropriate safety, health, and environmental practices and determine the applicability of regulatory limitations before use.*
- 4.2 Obtain a minimum of 1 gal. of hydrated lime in a sealed container from a fresh supply of an approved source from the Department's Material Producer List unless otherwise directed by the lab or project Engineer.
- 4.3 When testing materials for Part I, sample a minimum of 100 lb. in accordance with [Tex-100-E](#) for soils or [Tex-400-A](#) for flexible base and prepare in accordance with [Tex-101-E](#), Part II.
- 4.4 When testing materials for Part II, sample a minimum of 300 lb. in accordance with [Tex-100-E](#) for soils or [Tex-400-A](#) for flexible base and prepare in accordance with [Tex-101-E](#), Part II.
- 4.5 When reclaimed asphalt pavement (RAP) is greater than 1-3/4 in., resize the RAP to pass the 1-3/4 in. sieve.
Note 1-Heating the RAP to a maximum temperature of 140°F can assist in resizing the RAP.
- 4.6 When testing material from the roadway after reclamation and mixing, sample a minimum of 100 lb. of the treated material before the start of compaction.
- 4.6.1 Screen the lime treated material using a 7/8 in. sieve and a 1/4 in. sieve at the field moisture content, without drying.
- 4.6.2 Separate the material retained on the sieve from the material passing the sieve.
- 4.6.3 Cover the materials to retain field moisture.
-

PART I—MOISTURE-DENSITY CURVE

5. PROCEDURE

- 5.1 *This test procedure does not claim to address the safety concerns associated with its use. It is the responsibility of the user of this test procedure to establish the appropriate safety, health, and environmental practices and determine the applicability of regulatory limitations before use.*

- 5.2 Select a percentage of lime.
- 5.3 Determine the optimum moisture content and maximum dry density (M-D) curve for the material prepared from Section 4 in accordance with the applicable Sections of [Tex-113-E](#).
- 5.3.1 Before compaction of [Tex-113-E](#), add the lime uniformly to ensure even distribution of the lime throughout the sample. The amount of lime added is a percentage based on the dry weight of the material to be treated.
- 5.4 *Using Roadway Mixed and Treated Material.*
- 5.4.1 Recombine the material from Section 4 to produce samples for laboratory compaction.
- 5.4.2 Determine the M-D curve for this material in accordance with the applicable Sections of [Tex-113-E](#). Alternatively, compact samples to only verify a M-D curve that was produced from laboratory prepared materials in Section 5.3.
- 5.4.2.1 Estimate the field moisture content. Place material in a pan and weigh to the nearest 0.001 lb.
- 5.4.2.2 Adjust the moisture content of material by adding or removing moisture as needed. When removing moisture, do not oven dry the material. Stir frequently and as needed to achieve the necessary weight of material.
- 5.4.2.3 Determine the mass of material needed to achieve the desired moisture content.
- 5.4.2.4 Weigh material to the nearest 0.001 lb.

6. TEST REPORT

- 6.1 Lime Content, 0.1%;
- 6.2 Optimum Moisture Content, 0.1%; and
- 6.3 Maximum Dry Density, 0.1 pcf.

PART II—MIXTURE DESIGN TO DETERMINE THE TARGET LIME CONTENT

7. PROCEDURE

- 7.1 *This test procedure does not claim to address the safety concerns associated with its use. It is the responsibility of the user of this test procedure to establish the appropriate safety, health, and environmental practices and determine the applicability of regulatory limitations before use.*
- 7.2 Determine the lime content to achieve a pH of 12.4 or higher in accordance with Part III.

- 7.3 Determine the optimum moisture content and maximum dry density (M-D curve) at this lime content for the material prepared from Section 4 in accordance with the applicable Sections of [Tex-113-E](#). A higher lime content may be used.
- 7.3.1 Before compaction of [Tex-113-E](#), add the lime uniformly to ensure even distribution of the lime throughout the sample. The amount of lime added is a percentage based on the dry weight of the material to be treated.
- 7.4 Recombine the material prepared from Section 4 and mold three samples using the M-D curve from Section 7.3.
- 7.5 Place a card on each specimen labeling the laboratory identification number and the percent of lime.
- 7.6 Proceed to Section 7.8 for curing the specimens.
- 7.7 *Using Roadway Mixed and Treated Material to Verify UCS.*
- 7.7.1 Recombine the material from Section 4.6 and mold three samples in accordance with the applicable Sections of [Tex-113-E](#).
- 7.7.2 Estimate the field moisture content. Place material in a pan and weigh to the nearest 0.001 lb.
- 7.7.3 When necessary, adjust the moisture content of material by adding or removing moisture as needed. When removing moisture, do not oven dry the material. Stir frequently and as needed to achieve the necessary weight of material.
- 7.7.4 Determine the mass of material needed to achieve the desired moisture content.
- 7.7.5 Weigh material to the nearest 0.001 lb.
- 7.8 *Curing*
- 7.8.1 Place the compacted specimens in triaxial cells.
- 7.8.2 Enclose the specimens with top and bottom porous stones and store on a countertop for seven days at room temperature.
- 7.9 After seven days of curing, remove the specimens from the triaxial cells.
- 7.9.1 Remove the top porous stone, and place them in an oven with the bottom porous stone only at a maximum temperature of 140°F until 1/3 to 1/2 of the molding moisture has been removed.
- 7.9.1.1 Measure the moisture content from weighing a sample before and after drying periods of time, such as hourly or as deemed necessary to achieve the 1/3 to 1/2 molding moisture. Allow the specimens to cool to room temperature.
- 7.10 Weigh the specimens to the nearest 0.001 lb. and measure the sample height with the micrometer dial assembly to the nearest 0.001 in.
- 7.11 Enclose the specimens in triaxial cells, with top and bottom porous stones.

- 7.12 Subject the specimens to capillary rise for ten days in accordance with [Tex-117-E](#), Sections 5.8-5.13, Figure 1, and Table 1.
- 7.13 Measure the unconfined compressive strength (UCS) in accordance with the applicable Sections of [Tex-117-E](#), Part II.
- 7.14 When testing lime treated soil, if the UCS is less than 50 psi or less than the minimum UCS as shown on plans, a new mixture design is required. Proceed to Section 7.3 and add a minimum of one additional percent of lime to the soil.
- 7.15 When testing lime treated soil blended with existing materials, or lime treated flexible base, or lime treated flexible base blended with existing materials, if the UCS is less than 150 psi or less than the minimum UCS as shown on plans, a new mixture design is required. Proceed to Section 7.3 and add a minimum of one additional percent of lime to the material.

8. TEST REPORT

- 8.1 Target Lime Content, 0.1%.
- 8.2 Optimum Moisture Content, 0.1%;
- 8.3 Maximum Dry Density, 0.1 pcf; and
- 8.4 Unconfined Compressive Strength, nearest whole psi.

PART III—PH SERIES

9. PROCEDURE

- 9.1 *This test procedure does not claim to address the safety concerns associated with its use. It is the responsibility of the user of this test procedure to establish the appropriate safety, health, and environmental practices and determine the applicability of regulatory limitations before use.*
- 9.2 Prepare the sample in accordance with [Tex-128-E](#).
- 9.3 Weigh 30 ± 0.01 g of the sample and place it in a clean container. Repeat five additional times to weigh up a total of six test samples in six different containers.
- 9.4 Weigh 0.6 ± 0.01 g of lime which is 2% of the dry sample weight of 30 g and combine it with one of the samples from Section 9.2.
- 9.5 Repeat this for lime contents of 4, 6, 8, and 10% by adding 1.2 ± 0.01 , 1.8 ± 0.01 , 2.4 ± 0.01 , and 3.0 ± 0.01 g of lime, respectively, into a sample from Section 9.2. One sample from Section 9.2 will not be combined with any lime and tested as is at 0% lime.
- 9.6 Measure the pH of each sample from Section 9.3 and 9.4 in accordance with [Tex-128-E](#).

- 9.6.1 When the pH readings are 12.4 or higher, the sample with the lowest percentage of lime is the percent required to treat the material.
 - 9.6.2 When the pH readings do not go above 12.3 and two or more samples give this reading, the sample with the lowest percentage of lime is the percent required to treat the material.
 - 9.6.3 When the highest pH reading is 12.3 and only the sample with the highest percentage of lime achieves this, additional testing is required using higher percentages of lime.
-

10. **TEST REPORT**

- 10.1 Lime Treated Sample pH, 0.1%.

Test Procedure for**LABORATORY CLASSIFICATION OF SOILS FOR
ENGINEERING PURPOSES****TxDOT Designation: Tex-142-E****Effective Date: August 1999**

1. SCOPE

- 1.1 This method is a system for classifying disturbed and undisturbed soils based on laboratory determination of liquid limit, plasticity index, and particle-size characteristics.
- 1.1.1 This method of soil classification is similar to the ASTM version of the Unified Soils Classification System (USCS). This classification system identifies three major soil groups: coarse-grained soils, fine-grained soils, and highly organic soils.
- 1.1.2 Based on visual observations and prescribed laboratory tests, a soil is assigned a group symbol(s) and names and thereby classified.
- 1.1.3 There are other parameters such as unconfined compressive strength, dry unit weight, and water content, which can be used in conjunction with this method to provide detailed description of undisturbed soil samplers.
- 1.2 The values given in parentheses (if provided) are not standard and may not be exact mathematical conversions. Use each system of units separately. Combining values from the two systems may result in nonconformance with the standard.
-

2. DEFINITIONS

- 2.1 *Plasticity Chart*—A plasticity chart is used to differentiate the plasticity and organic characteristics of the fine-grained soils based on liquid limit (LL) and plasticity index (PI) of the soils.
- 2.2 *A-Line*—On the plasticity chart, A-line is a sloped line beginning at $PI = 4$ and $LL = 25.5$ with an equation of $PI = 0.73 (LL - 20)$.
- 2.3 *Clay*—Clay is a fine grained soil that can be made to exhibit plasticity (putty-like properties) within a range of water contents and that exhibits considerable strength when air dry.
- 2.4 *Silt*—Silt is soil passing the No. 200 (75 μm) sieve that is non-plastic or very slightly plastic and that exhibits little or no strength when air dry.
-

- 2.5 *Organic Clay*—Organic clay is a soil that would be classified as a clay except that its LL after oven drying (dry sample preparation) is less than 75% of its LL before oven drying (wet sample preparation).
- 2.6 *Organic Silt*—Organic silt is a soil that would be classified as a silt except that its LL after oven drying (dry sample preparation) is less than 75% of its LL before oven drying (wet sample preparation).
- 2.7 *Peat*—Peat is a soil composed of vegetable tissue in various stages of decomposition usually with a dark brown to black color, a spongy consistency, and a texture ranging from fibrous to amorphous.
- 2.8 *Gravel*—Gravel consists of unconsolidated or loose detrital sediment (aggregate resulting from natural disintegration and abrasion of rock) with particle sizes passing the 3 in. (76.2 mm) sieve and retained on the No. 10 (2.00 mm) sieve.
- 2.9 *Sand*—Sand consists of fine aggregate particles that are retained on the No. 200 (75 μ m) sieve, either as natural sand resulting from natural disintegration and abrasion of rock, or as manufactured sand, which is produced by the crushing of rock, gravel, slag, etc.
- 2.10 *Coefficient of Curvature, C_c*—Coefficient of Curvature is the ratio $(D_{30})^2 / (D_{10} \bullet D_{60})$, where D_{60} , D_{30} , and D_{10} are the particle diameters corresponding to 60, 30, and 10% finer on the cumulative particle-size distribution curve, respectively.
- 2.11 *Coefficient of Uniformity, C_u*—Coefficient of Uniformity is the ratio (D_{60}/D_{10}) , where D_{60} and D_{10} are the particle diameters corresponding to 60 and 10% finer on the cumulative particle-size distribution curve, respectively.

3. PREPARING SOIL FOR CLASSIFICATION

- 3.1 Before a sample can be classified according to this test method, determine the particle-size distribution of the minus 3 in. (75 mm) sieve and minus No. 4 (4.75 mm) sieve material and the soils constants (LL, PL & PI) of the minus No. 40 (425 μ m) sieve material.
- 3.2 Use the following test methods to determine these parameters:
- Tex-110-E
 - Tex-104-E
 - Tex-105-E
 - Tex-106-E.
- 3.2.1 Following are the criteria for assigning group symbols and group names using laboratory test results.
- 3.2.1.1 *Coarse-Grained Soil*—More than 50% by dry weight is retained on the No. 200 (75 μ m) sieve.

Table 1—Gravels – More than 50% of Plus No. 200 (75 µm) Retained on the No. 4 (4.75 mm) Sieve

		Symbol	Group Name
Clean Gravel – less than 5% fines	$Cu \geq 4 \ \& \ 1 \leq Cc \leq 3$	GW	Well-graded gravel
	$Cu < 4 \ \&/or \ 1 > Cc > 3$	GP	Poorly graded gravel
Gravel with fines – 5 to 12% clay fines	$Cu \geq 4 \ \& \ 1 \leq Cc \leq 3$	GW-GC	Well-graded gravel with clay
	$Cu < 4 \ \&/or \ 1 > Cc > 3$	GP-GC	Poorly graded gravel with clay
Gravel with fines – 5 to 12% silt fines	$Cu \geq 4 \ \& \ 1 \leq Cc \leq 3$	GW-GM	Well-graded gravel with silt
	$Cu < 4 \ \&/or \ 1 > Cc > 3$	GP-GM	Poorly graded gravel with silt
Gravel with more than 12% fines	Fines classified as CL or CH	GC	Clayey Gravel
	Fines classified as ML or MH	GM	Silty Gravel

Note: If gravel contains $\geq 15\%$ sand, add “with sand” after group name. If fines are organic, add “with organic fines” after the group name.

Table 2—Sands – 50% or More of Plus No. 200 (75 µm) Passes the No. 4 (4.75mm) Sieve

		Symbol	Group Name
Clean Sands - less than 5% fines	$Cu \geq 6 \ \& \ 1 \leq Cc \leq 3$	SW	Well-graded sand
	$Cu < 6 \ \&/or \ 1 > Cc > 3$	SP	Poorly graded sand
Sand with 5 to 12% clay fines	$Cu \geq 6 \ \& \ 1 \leq Cc \leq 3$	SW-SC	Well-graded sand with clay
	$Cu < 6 \ \&/or \ 1 > Cc > 3$	SP-SC	Poorly graded sand with clay
Sand with 5 to 12% silt fines	$Cu \geq 6 \ \& \ 1 \leq Cc \leq 3$	SW-SM	Well-graded sand with silt
	$Cu < 6 \ \&/or \ 1 > Cc > 3$	SP-SM	Poorly graded sand with silt
Sand with more than 12% fines	Fines classified as CL or CH	SC	Clayey Sand
	Fines classified as ML or MH	SM	Silty Sand

Note: If sand contains $\geq 15\%$ gravel, add “with gravel” after group name. If fines are organic, add “with organic fines” after group name.

3.2.1.2 *Fine-Grained Soil*—50% or more passes the No. 200 (75 μm) sieve.

Table 3—Silts and Clays – Liquid Limit Less than 50% & Have Less than 15% Material Retained on No. 200 (75 μm) Sieve

		Symbol	Group Name
Inorganic	PI > 7 & plots on or above "A" line	CL	Lean Clay
	PI < 4 or plots below "A" line	ML	Silt
	4 < PI < 7 & plots on or above "A" line	CL-ML	Silty Clay
Organic - defined by (LL-oven dried)/(LL-not dried) < 0.75	PI ≥ 4 & plots on or above "A" line	OL	Organic Clay
	PI < 4 or plots below "A" line		Organic Silt

Note: If soil contains 15 to 29% plus No. 200 (75 μm), add "with sand" or "with gravel" after group name, whichever is predominant. If soil contains 30% or more plus No. 200 (75 μm), predominantly sand, add "sandy" before group name. If soil contains 30% or more plus No. 200 (75 μm), predominantly gravel, add "gravelly" before group name.

Examples:

- (CL) lean clay w/sand; lean clay w/gravel; sandy lean clay; sandy lean clay w/gravel; gravelly lean clay; etc.
- (CL-ML) silty clay w/sand; silty clay w/gravel; sandy silty clay; sandy silty clay w/gravel; gravelly silty clay; etc.
- (ML) silt w/sand; silt w/gravel; sandy silt; sandy silt w/gravel; gravelly silt w/sand
- (OL) organic clay w/sand; organic clay w/gravel; sandy organic clay; sandy organic clay w/gravel; etc.
- (OL) organic silt w/sand; organic silt w/gravel; sandy organic silt; sandy organic silt w/gravel; etc.

Table 4—Silts and Clays – Liquid Limit of 50% or More & Have Less than 15% Material Retained on No. 200 (75 µm) Sieve

		Symbol	Group Name
Inorganic	PI plots on or above "A" line	CH	Fat Clay
	PI plots below "A" line	MH	Elastic Silt
Organic – defined by (LL-oven dried)/(LL-not dried)<0.75	PI plots on or above "A" line	OH	Organic Clay
	PI plots below "A" line	OH	Organic Silt

Note: If soil contains 15 to 29% plus No. 200 (75 µm), add "with sand" or "with gravel" after group name, whichever is predominant. If soil contains 30% or more plus No. 200 (75 µm), predominantly sand, add "sandy" before group name. If soil contains 30% or more plus No. 200 (75 µm), predominantly gravel, add "gravelly" before group name. (CH) fat clay w/sand; fat clay w/gravel; sandy fat clay; sandy fat clay w/gravel; gravelly fat clay; etc.

Examples:

- (MH) elastic silt w/sand; elastic silt w/gravel; sandy elastic silt; sandy elastic silt w/gravel; etc.
- (OH) organic clay w/sand; organic clay w/gravel; sandy organic clay; sandy organic clay w/gravel; etc.
- (OH) organic silt w/sand; organic silt w/gravel; sandy organic silt; sandy organic silt w/gravel; etc.

4. PROCEDURE

4.1 Determine the LL, PL, and PI of the soil in accordance with:

- Tex-104-E
- Tex-105-E
- Tex-106-E.

4.2 Determine the water content of the soil in accordance with Tex-103-E.

4.3 Determine the amount of material passing the No. 200 (75 µm) sieve in accordance with Tex-110-E for fine-grained soil, or Tex-401-A for coarse-grained soil.

4.4 Determine the particle size distribution of the materials retained on the No. 200 (75 µm) sieve in accordance with Tex-406-A decantation tests for concrete aggregates.

4.5 Use Figure 1, LL, PI, percent material passing the No. 200 (75 µm) sieve, and Cu and Cc, and classify the soil with group name and description with group symbol.

Note 1—Other than soil constants and particle size distribution, there are other engineering properties that can be measured in either the field or laboratory in conjunction with this classification system to provide a more complete description of the soil characteristics.

Note 2—In general, there is a close correlation among the soil classification and the engineering properties such as consistency, density, water content, and dry unit weight. When available, this information should be used in conjunction with soil classification to aid in the evaluation of the soil's significant properties for engineering use.

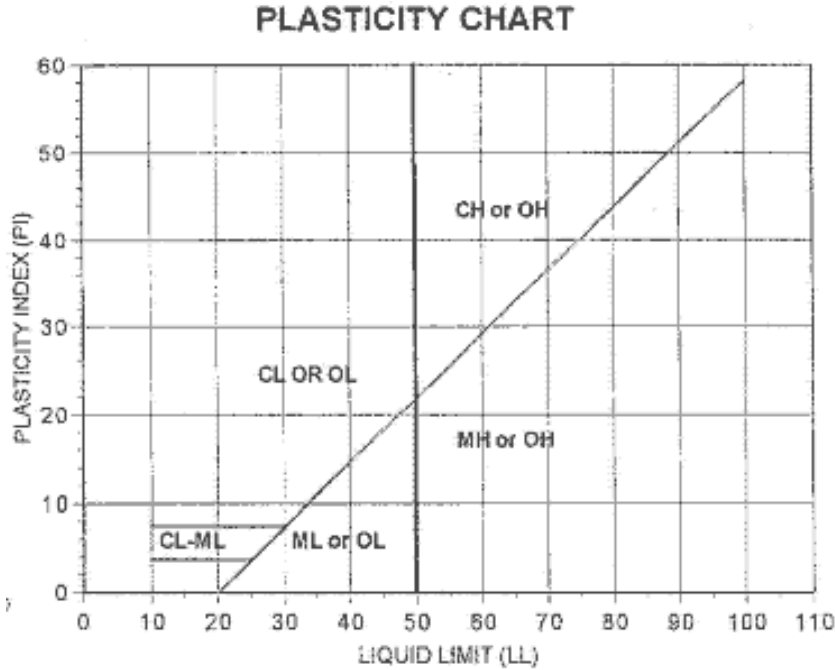

Figure 1—Plasticity Chart

5. CONSISTENCY

5.1 The consistency of a predominantly clay and/or silt is defined by its unconfined compressive (UC) strength when tested in the laboratory under the normal moisture condition in an undisturbed condition. Typically, one would find higher water content associated with lower unconfined compressive strength or softer material, and lower water content associated with a higher unconfined compressive strength or harder material.

5.2 Table 5 classifies soil by unconfined compressive strength.

Table 5—Soil Consistency

UC kg/cm2 (tsf)	Consistency
less than 0.25	Very Soft
0.25 to 0.5	Soft
0.5 to 1.0	Medium Stiff
1.0 to 2.0	Stiff
2.0 to 4.0	Very Stiff
greater than 4.0	Hard

6. DENSITY

6.1 Soil density as typically measured by the N-Value of in-situ Standard Penetration Test (SPT) or the Texas Cone Penetration Test (TCP) is an indication of the relative compactness and bearing capacity of a predominantly granular material such as sand, clayey sand, silty sand, and gravelly material. The water content of a granular material is mostly unimportant because the bearing strength is independent of water content, and the water content of a disturbed sample is not representative of the material.

6.2 Table 6 classifies soil by density.

Table 6—Soil Density

SPT N Value	TCP Blows/0.3 m (12 in.)	Density
less than 4	less than 8	Very Loose
4 to 10	8 to 20	Loose
10 to 30	20 to 60	Medium Dense
30 to 50	60 to 100	Dense
Greater than 50	greater than 100	Very Dense

7. DRY UNIT WEIGHT

7.1 Dry unit weight of the material usually increases with decreasing plasticity and/or increasing percentage of coarse-grained particles in the soils. One can usually find a higher than usual water content and lower dry unit weight in an organic material. The more plastic material such as clay has a greater propensity to hold water and therefore has a higher water content and lower dry unit weight.

7.2 Table 7 indicates the dry unit weight for soil types.

Table 7—Dry Unit Weight for Soil Types

Dry Unit Weight Kg/m3 (pcf)	Soil Type (Group Symbol)
0.77–1.03 (60–80)	Organic Clay (OH)
1.03–1.22 (80–95)	Clay (CH)
1.16–1.35 (90–105)	Clay (CL)
1.22–1.42 (95–110)	Sandy Clay (CL)
1.29–1.55 (100–120)	Clayey Sand (SC)

Item 247

Flexible Base



1. DESCRIPTION

Construct a foundation course composed of flexible base.

2. MATERIALS

Furnish uncontaminated materials of uniform quality that meet the requirements of the plans and specifications. Notify the Engineer of the proposed material sources and of changes to material sources. The Engineer may sample and test project materials at any time before compaction throughout the duration of the project to assure specification compliance. Use Tex-100-E material definitions.

- 2.1. **Aggregate.** Furnish aggregate of the type and grade shown on the plans and meeting the requirements of Table 1. Each source must meet Table 1 requirements for liquid limit, plasticity index, and wet ball mill for the grade specified. Do not use additives, such as but not limited to lime, cement, or fly ash to modify aggregates to meet the requirements of Table 1 unless shown on the plans.

Table 1
Material Requirements

Property	Test Method	Grade 1-2	Grade 3	Grade 4 ²	Grade 5
Sampling	Tex-400-A				
Master gradation sieve size (cumulative % retained)	Tex-110-E			As shown on the plans	
2-1/2"		0	0		0
1-3/4"		0-10	0-10		0-5
7/8"		10-35	-		10-35
3/8"		30-65	-		35-65
#4		45-75	45-75		45-75
#40	65-90	50-85	70-90		
Liquid Limit, % Max	Tex-104-E	40	40	As shown on the plans	35
Plasticity Index, Max ¹	Tex-106-E	10	12	As shown on the plans	10
Plasticity index, Min ¹		As shown on the plans	As shown on the plans	As shown on the plans	As shown on the plans
Wet ball mill, % Max	Tex-116-E	40	-	As shown on the plans	40
Wet ball mill, % Max increase passing the #40 sieve		20	-	As shown on the plans	20
Min compressive strength, psi	Tex-117-E			As shown on the plans	
lateral pressure 0 psi		35	-		-
lateral pressure 3 psi		-	-		90
lateral pressure 15 psi		175	-		175

- Determine plastic index in accordance with Tex-107-E (linear shrinkage) when liquid limit is unattainable as defined in Tex-104-E.
- Grade 4 may be further designated as Grade 4A, Grade 4B, etc.

- 2.1.1. **Material Tolerances.** The Engineer may accept material if no more than 1 of the 5 most recent gradation tests has an individual sieve outside the specified limits of the gradation.

When target grading is required by the plans, no single failing test may exceed the master grading by more than 5 percentage points on sieves No. 4 and larger or 3 percentage points on sieves smaller than No. 4.

The Engineer may accept material if no more than 1 of the 5 most recent plasticity index tests is outside the specified limit. No single failing test may exceed the allowable limit by more than 2 points.

- 2.1.2. **Material Types.** Do not use fillers or binders unless approved. Furnish the type specified on the plans in accordance with the following:
- 2.1.2.1. **Type A.** Crushed stone produced and graded from oversize quarried aggregate that originates from a single, naturally occurring source. Do not use gravel or multiple sources.
- 2.1.2.2. **Type B.** Crushed or uncrushed gravel. Blending of 2 or more sources is allowed.
- 2.1.2.3. **Type C.** Crushed gravel with a minimum of 60% of the particles retained on a No. 4 sieve with 2 or more crushed faces as determined by Tex-460-A, Part I. Blending of 2 or more sources is allowed.
- 2.1.2.4. **Type D.** Type A material or crushed concrete. Crushed concrete containing gravel will be considered Type D material. Crushed concrete must meet the requirements in Section 247.2.1.3.2., "Recycled Material (Including Crushed Concrete) Requirements," and be managed in a way to provide for uniform quality. The Engineer may require separate dedicated stockpiles in order to verify compliance.
- 2.1.2.5. **Type E.** Caliche, iron ore or as otherwise shown on the plans.
- 2.1.3. **Recycled Material.** Reclaimed asphalt pavement (RAP) and other recycled materials may be used when shown on the plans. Request approval to blend 2 or more sources of recycled materials.
- 2.1.3.1. **Limits on Percentage.** Do not exceed 20% RAP by weight, when RAP is allowed, unless otherwise shown on the plans. The percentage limitations for other recycled materials will be as shown on the plans.
- 2.1.3.2. **Recycled Material (Including Crushed Concrete) Requirements.**
- 2.1.3.2.1. **Contractor-Furnished Recycled Materials.** Provide recycled materials, other than RAP, that have a maximum sulfate content of 3,000 ppm when tested in accordance with Tex-145-E. When the Contractor furnishes the recycled materials, including crushed concrete, the final product will be subject to the requirements of Table 1 for the grade specified. Certify compliance with DMS-11000, "Evaluating and Using Nonhazardous Recyclable Materials Guidelines," for Contractor furnished recycled materials. In addition, recycled materials must be free from reinforcing steel and other objectionable material and have at most 1.5% deleterious material when tested in accordance with Tex-413-A. For RAP, do not exceed a maximum percent loss from decantation of 5.0% when tested in accordance with Tex-406-A. Test RAP without removing the asphalt.
- 2.1.3.2.2. **Department-Furnished Required Recycled Materials.** When the Department furnishes and requires the use of recycled materials, unless otherwise shown on the plans:
- Department-required recycled material will not be subject to the requirements in Table 1,
 - Contractor-furnished materials are subject to the requirements in Table 1 and this Item,
 - the final product, blended, will be subject to the requirements in Table 1, and
 - for final product, unblended (100% Department-furnished required recycled material), the liquid limit, plasticity index, wet ball mill, and compressive strength is waived.
- Crush Department-furnished RAP so that 100% passes the 2 in. sieve. The Contractor is responsible for uniformly blending to meet the percentage required.
- 2.1.3.2.3. **Department-Furnished and Allowed Recycled Materials.** When the Department furnishes and allows the use of recycled materials or allows the Contractor to furnish recycled materials, the final blended product is subject to the requirements of Table 1 and the plans.

- 2.1.3.3. **Recycled Material Sources.** Department-owned recycled material is available to the Contractor only when shown on the plans. Return unused Department-owned recycled materials to the Department stockpile location designated by the Engineer unless otherwise shown on the plans.

The use of Contractor-owned recycled materials is allowed when shown on the plans. Contractor-owned surplus recycled materials remain the property of the Contractor. Remove Contractor-owned recycled materials from the project and dispose of them in accordance with federal, state, and local regulations before project acceptance. Do not intermingle Contractor-owned recycled material with Department-owned recycled material unless approved.

- 2.2. **Water.** Furnish water free of industrial wastes and other objectionable matter.
- 2.3. **Material Sources.** Expose the vertical faces of all strata of material proposed for use when non-commercial sources are used. Secure and process the material by successive vertical cuts extending through all exposed strata, when directed.

3. EQUIPMENT

Provide machinery, tools, and equipment necessary for proper execution of the work.

- 3.1. Provide rollers in accordance with Item 210, "Rolling." Provide proof rollers in accordance with Item 216, "Proof Rolling," when required.
- 3.2. When ride quality measurement is required, provide a high speed or lightweight inertial profiler certified at the Texas A&M Transportation Institute. Provide equipment certification documentation. Display a current decal on the equipment indicating the certification expiration date.

4. CONSTRUCTION

Construct each layer uniformly, free of loose or segregated areas, and with the required density and moisture content. Provide a smooth surface that conforms to the typical sections, lines, and grades shown on the plans or as directed.

Stockpile base material temporarily at an approved location before delivery to the roadway. Build stockpiles in layers no greater than 2 ft. thick. Stockpiles must have a total height between 10 and 16 ft. unless otherwise approved. After construction and acceptance of the stockpile, loading from the stockpile for delivery is allowed. Load by making successive vertical cuts through the entire depth of the stockpile.

Do not add or remove material from temporary stockpiles that require sampling and testing before delivery unless otherwise approved. Charges for additional sampling and testing required as a result of adding or removing material will be deducted from the Contractor's estimates.

Haul approved flexible base in clean trucks. Deliver the required quantity to each 100-ft. station or designated stockpile site as shown on the plans. Prepare stockpile sites as directed. When delivery is to the 100-ft. station, manipulate in accordance with the applicable Items.

- 4.1. **Preparation of Subgrade or Existing Base.** Remove or scarify existing asphalt concrete pavement in accordance with Item 105, "Removing Treated and Untreated Base and Asphalt Pavement," when shown on the plans or as directed. Shape the subgrade or existing base to conform to the typical sections shown on the plans or as directed.

When new base is required to be mixed with existing base, deliver, place, and spread the new flexible base in the required amount per station. Manipulate and thoroughly mix the new base with existing material to provide a uniform mixture to the specified depth before shaping.

Proof roll the roadbed in accordance with Item 216, "Proof Rolling," before pulverizing or scarifying when shown on the plans or directed. Correct soft spots as directed.

- 4.2. **Placing.** Spread and shape flexible base into a uniform layer with an approved spreader the same day as delivered unless otherwise approved. Construct layers to the thickness shown on the plans. Maintain the shape of the course. Control dust by sprinkling, as directed. Correct or replace segregated areas as directed, at no additional expense to the Department.

Place successive base courses and finish courses using the same construction methods required for the first course.

- 4.3. **Compaction.** Compact using density control unless otherwise shown on the plans. Multiple lifts are permitted when shown on the plans or approved. Bring each layer to the moisture content directed. When necessary, sprinkle the material in accordance with Item 204, "Sprinkling."

Begin rolling longitudinally at the sides and proceed towards the center, overlapping on successive trips by at least 1/2 the width of the roller unit. Begin rolling at the low side and progress toward the high side on superelevated curves. Offset alternate trips of the roller. Operate rollers at a speed between 2 and 6 mph as directed.

Rework, recompact, and refinish material that fails to meet or that loses required moisture, density, stability, or finish requirements before the next course is placed or the project is accepted. Continue work until specification requirements are met. Perform the work at no additional expense to the Department.

Before final acceptance, the Engineer will select the locations of tests and measure the flexible base depth in accordance with Tex-140-E. Correct areas deficient by more than 1/2 in. in thickness by scarifying, adding material as required, reshaping, recompacting, and refinishing at the Contractor's expense.

- 4.3.1. **Ordinary Compaction.** Roll with approved compaction equipment as directed. Correct irregularities, depressions, and weak spots immediately by scarifying the areas affected, adding or removing approved material as required, reshaping, and recompacting.

- 4.3.2. **Density Control.** Compact to at least 100% of the maximum dry density determined by Tex-113-E, unless otherwise shown on the plans. Maintain moisture during compaction within ± 2 percentage points of the optimum moisture content as determined by Tex-113-E. Measure the moisture content of the material in accordance with Tex-115-E or Tex-103-E during compaction daily and report the results the same day to the Engineer, unless otherwise shown on the plans or directed. Do not achieve density by drying the material after compaction.

The Engineer will determine roadway density and moisture content of completed sections in accordance with Tex-115-E. The Engineer may accept the section if no more than 1 of the 5 most recent density tests is below the specified density and the failing test is no more than 3 pcf below the specified density.

- 4.4. **Finishing.** After completing compaction, clip, skin, or tight-blade the surface with a maintainer or subgrade trimmer to a depth of approximately 1/4 in. Remove loosened material and dispose of it at an approved location. Seal the clipped surface immediately by rolling with a pneumatic tire roller until a smooth surface is attained. Add small increments of water as needed during rolling. Shape and maintain the course and surface in conformity with the typical sections, lines, and grades as shown on the plans or as directed.

Correct grade deviations greater than 1/4 in. in 16 feet measured longitudinally or greater than 1/4 in. over the entire width of the cross-section in areas where surfacing is to be placed. Correct by loosening and adding, or removing material. Reshape and re-compact in accordance with Section 247.4.3., "Compaction."

- 4.5. **Curing.** Cure the finished section until the moisture content is at least 2 percentage points below optimum or as directed before applying the next successive course or prime coat.

- 4.6. **Ride Quality.** This section applies to the final travel lanes that receive a 1 or 2 course surface treatment for the final surface, unless otherwise shown on the plans. Measure ride quality of the base course after placement of the prime coat and before placement of the surface treatment, unless otherwise approved. Use a certified profiler operator from the Department's MPL. When requested, furnish the Engineer documentation for the person certified to operate the profiler.

Provide all profile measurements to the Engineer in electronic data files within 3 days after placement of the prime coat using the format specified in Tex-1001-S. The Engineer will use Department software to evaluate longitudinal profiles to determine areas requiring corrective action. Correct 0.1-mi.sections having an average international roughness index (IRI) value greater than 100.0 in. per mile to an IRI value of 100.0 in. per mile or less for each wheel path, unless otherwise shown on the plans.

Re-profile and correct sections that fail to maintain ride quality until placement of the next course, as directed. Correct re-profiled sections until specification requirements are met, as approved. Perform this work at no additional expense to the Department.

5. MEASUREMENT

Flexible base will be measured as follows:

- **Flexible Base (Complete In Place).** The ton, square yard, or any cubic yard method.
- **Flexible Base (Roadway Delivery).** The ton or any cubic yard method.
- **Flexible Base (Stockpile Delivery).** The ton, cubic yard in vehicle, or cubic yard in stockpile.

Measurement by the cubic yard in final position and square yard is a plans quantity measurement. The quantity to be paid for is the quantity shown in the proposal unless modified by Article 9.2., "Plans Quantity Measurement." Additional measurements or calculations will be made if adjustments of quantities are required.

Measurement is further defined for payment as follows.

- 5.1. **Cubic Yard in Vehicle.** By the cubic yard in vehicles of uniform capacity at the point of delivery.
- 5.2. **Cubic Yard in Stockpile.** By the cubic yard in the final stockpile position by the method of average end areas.
- 5.3. **Cubic Yard in Final Position.** By the cubic yard in the completed and accepted final position. The volume of base course is computed in place by the method of average end areas between the original subgrade or existing base surfaces and the lines, grades, and slopes of the accepted base course as shown on the plans.
- 5.4. **Square Yard.** By the square yard of surface area in the completed and accepted final position. The surface area of the base course is based on the width of flexible base as shown on the plans.
- 5.5. **Ton.** By the ton of dry weight in vehicles as delivered. The dry weight is determined by deducting the weight of the moisture in the material at the time of weighing from the gross weight of the material. The Engineer will determine the moisture content in the material in accordance with Tex-103-E from samples taken at the time of weighing.

When material is measured in trucks, the weight of the material will be determined on certified scales, or the Contractor must provide a set of standard platform truck scales at a location approved by the Engineer. Scales must conform to the requirements of Item 520, "Weighing and Measuring Equipment."

6. PAYMENT

The work performed and materials furnished in accordance with this Item and measured as provided under "Measurement" will be paid for at the unit price bid for the types of work shown below. No additional payment

will be made for thickness or width exceeding that shown on the typical section or provided on the plans for cubic yard in the final position or square yard measurement.

Sprinkling and rolling, except proof rolling, will not be paid for directly but will be subsidiary to this Item unless otherwise shown on the plans. When proof rolling is shown on the plans or directed, it will be paid for in accordance with Item 216, "Proof Rolling."

Where subgrade is constructed under this Contract, correction of soft spots in the subgrade will be at the Contractor's expense. Where subgrade is not constructed under this Contract, correction of soft spots in the subgrade will be paid in accordance with pertinent Items or Article 4.4., "Changes in the Work."

- 6.1. **Flexible Base (Complete In Place).** Payment will be made for the type and grade specified. For cubic yard measurement, "In Vehicle," "In Stockpile," or "In Final Position" will be specified. For square yard measurement, a depth will be specified. This price is full compensation for furnishing materials, temporary stockpiling, assistance provided in stockpile sampling and operations to level stockpiles for measurement, loading, hauling, delivery of materials, spreading, blading, mixing, shaping, placing, compacting, reworking, finishing, correcting locations where thickness is deficient, curing, furnishing scales and labor for weighing and measuring, and equipment, labor, tools, and incidentals.
- 6.2. **Flexible Base (Roadway Delivery).** Payment will be made for the type and grade specified. For cubic yard measurement, "In Vehicle," "In Stockpile," or "In Final Position" will be specified. The unit price bid will not include processing at the roadway. This price is full compensation for furnishing materials, temporary stockpiling, assistance provided in stockpile sampling and operations to level stockpiles for measurement, loading, hauling, delivery of materials, furnishing scales and labor for weighing and measuring, and equipment, labor, tools, and incidentals.
- 6.3. **Flexible Base (Stockpile Delivery).** Payment will be made for the type and grade specified. For cubic yard measurement, "In Vehicle" or "In Stockpile" will be specified. The unit price bid will not include processing at the roadway. This price is full compensation for furnishing and disposing of materials, preparing the stockpile area, temporary or permanent stockpiling, assistance provided in stockpile sampling and operations to level stockpiles for measurement, loading, hauling, delivery of materials to the stockpile, furnishing scales and labor for weighing and measuring, and equipment, labor, tools, and incidentals.